

**COMPONENTS**

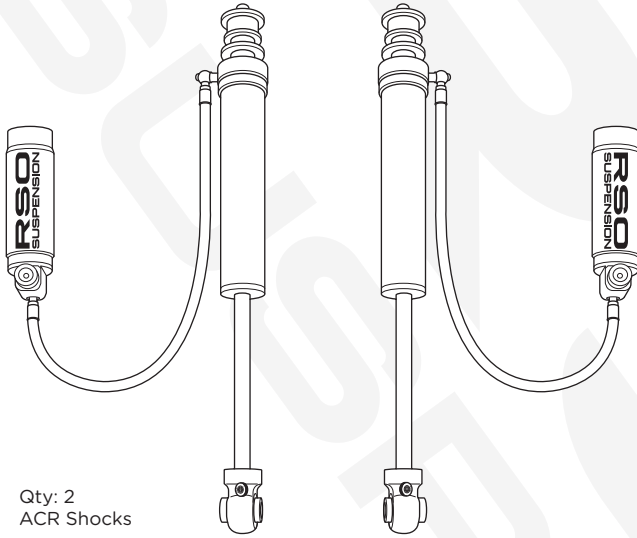

Qty: 2  
ACR Shocks

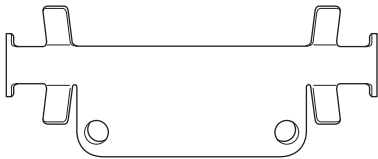

Qty: 2  
Remote Reservoir  
Mounting Bracket

**TOOLS REQUIRED**

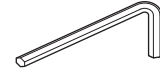

5mm  
Allen Wrench



Jack Stands

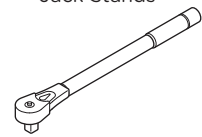

Torque Wrench

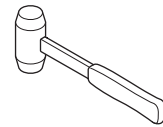

Small Sledge hammer

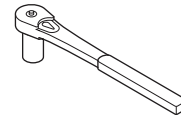

10mm, 12mm, 14mm, 19mm,  
20mm, 21mm and 27mm Socket

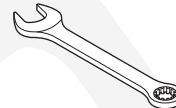

Open End Wrench

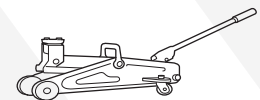

Jack

**INSTALLATION NOTES**

Lift Heights are based on factory vehicle height without any aftermarket accessories. Please note lift height range can vary depending on your accessories, aftermarket wheels, tires, gear and other suspension components you have added to your vehicle.

**NOTE:** If your vehicle came factory equipped with Kinetik Dynamic Suspension System (KDSS), the KDSS will need to be deactivated during any work completed on the suspension and reactivated once installation is completed. Please refer to the manufacturer's procedure to deactivate the system.

1. Using a correct weight rated jack, raise the rear of the vehicle and place jack stands on the vehicles jack points. Chock the front tires to ensure no movement while working under your vehicle. Once the back of the vehicle is off the ground and secured, remove the rear wheels.

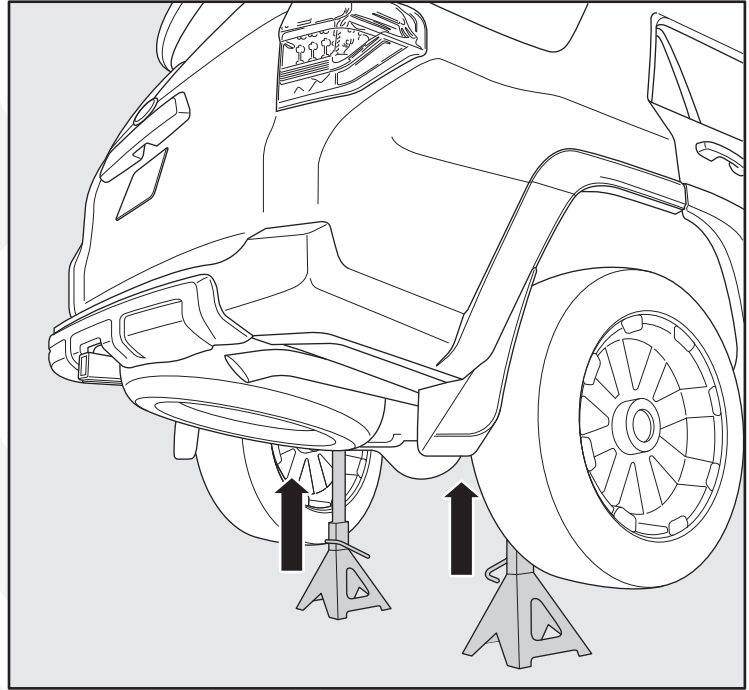

2. Using a hydraulic jack raise the rear axle to relieve tension on the rear shocks to make removal easier. Loosen and remove the lower shock bolt using a 17mm socket/wrench.

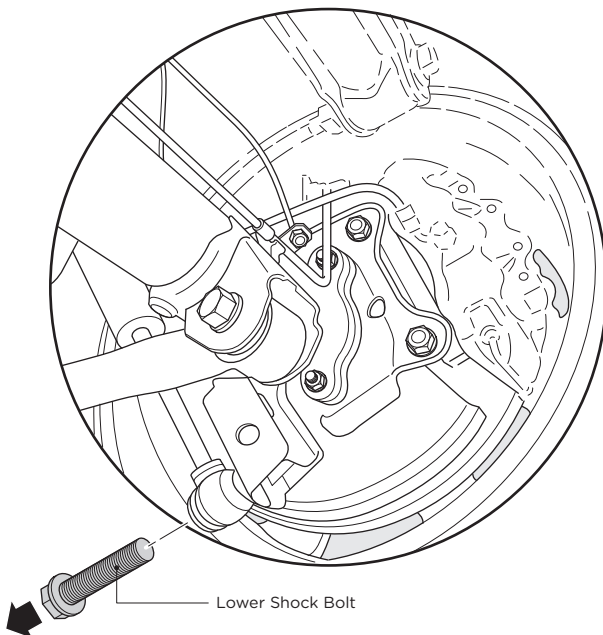

3. Make sure the axle is well supported, then remove the stem bushing nut and upper stem bushings using a 17mm socket/wrench. Remove the rear shock.

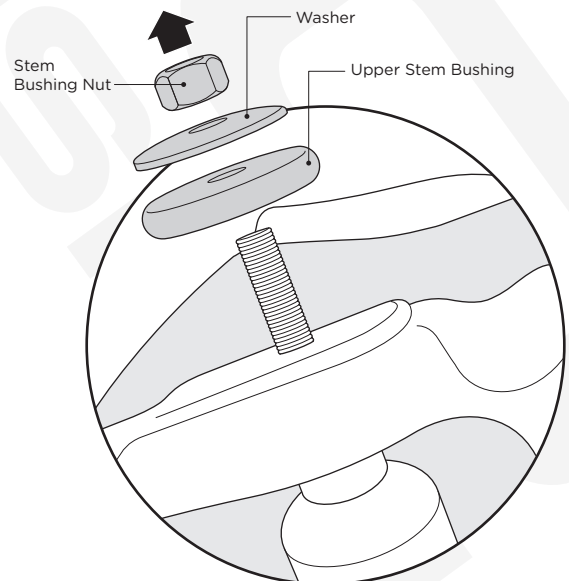

**4a.** Use a hydraulic jack to lift the axle and improve the approach angle to allow the shock to line up with the upper shock mounting bracket.

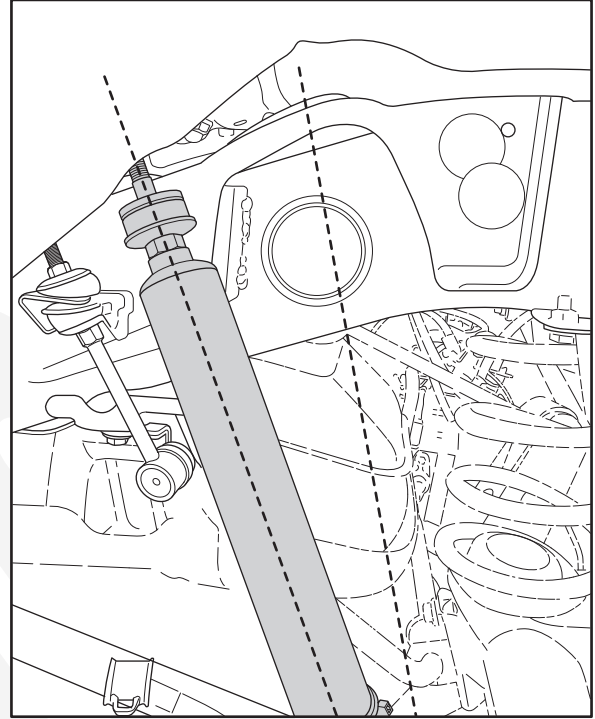

**4b.** The upper bar pin shock mount installs with the lower metal washer followed by a rubber bushing and then the thin center metal washer on the bottom of the shock mount.

Once the bar pin is pushed through the shock mounting bracket install the other rubber bushing followed by the large top metal washer and secure using the supplied 19mm Nylock nut.

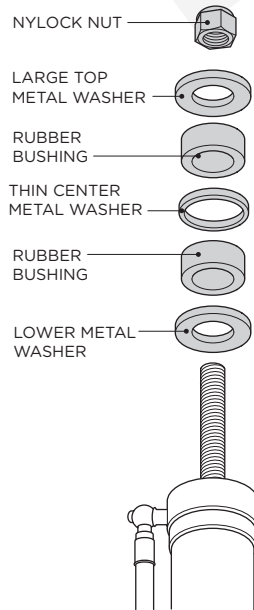

**4c.** Tighten the upper shock mount nut until the rubber bushing expands 5-10mm's.

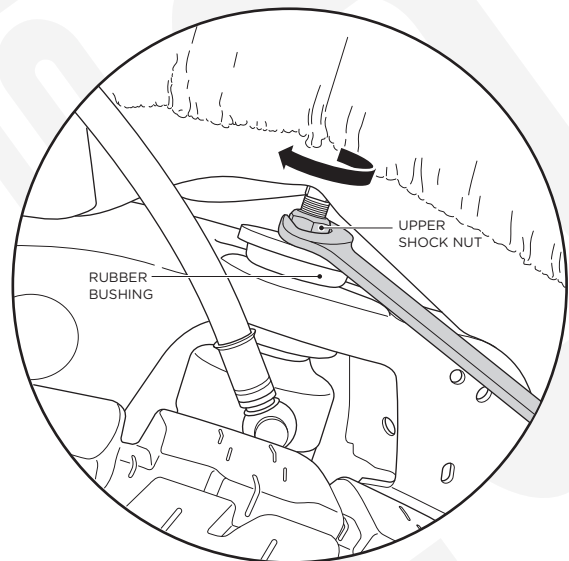

- 5a.** Lift the rear axle to improve angle of rear lower shock mounting post to make it easier to slide the shock's lower rod end on.

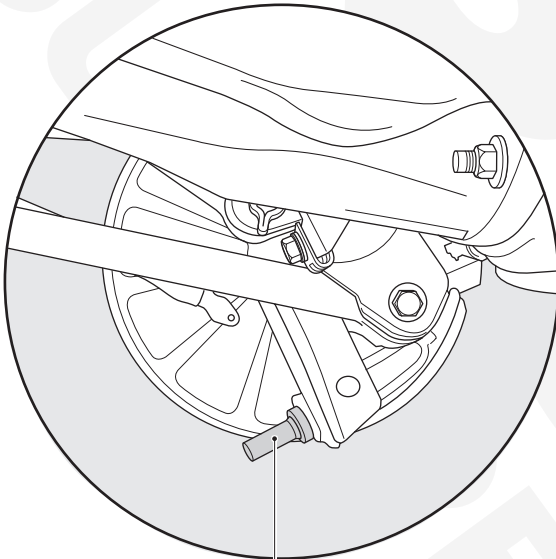

REAR LOWER SHOCK  
MOUNTING POST

- 5b.** Compress the shock and align the lower end with the factory lower shock mounting pin and bracket.

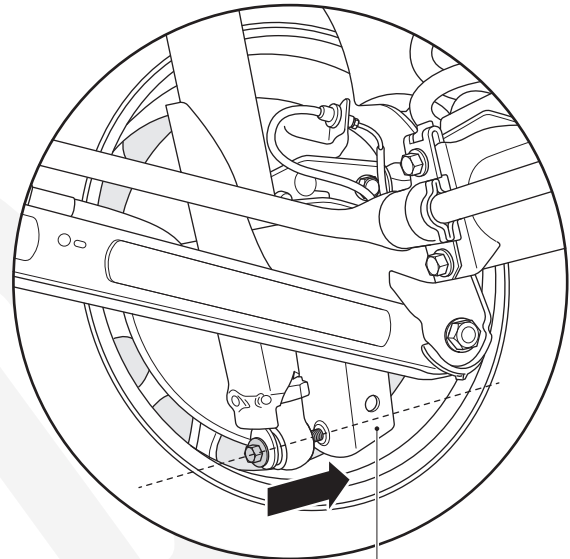

LOWER SHOCK  
MOUNTING BRACKET

- 6a.** The Remote Reservoir should be routed towards the back of the vehicle. Route the reservoir hose up and tight into the wheel well and away from the wheels and moving suspension components. Once you verified the reservoir hose will avoid contact mark the location and install the reservoir mounting bracket to the frame rail with the provided self tapping screws.

- 6b.** As a general guideline the tip of the reservoir will either be butted up against the back fender liner as shown in the image or just past it. Some trimming may be required. Mount the reservoir to the reservoir mounting bracket using the provided hose clamps, rotate the reservoir so the compression adjustment knob is accessible and tighten the hose clamps.

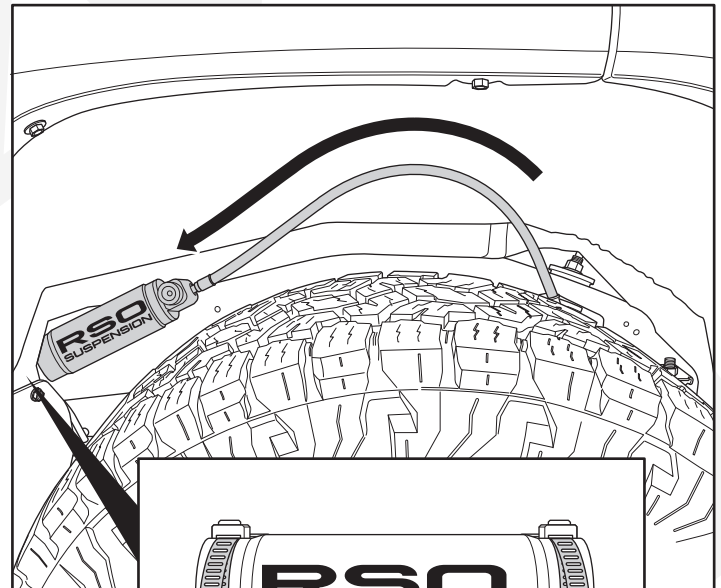

HOSE CLAMP

RESERVOIR MOUNTING  
BRACKET