

REAR SWAY BAR KIT

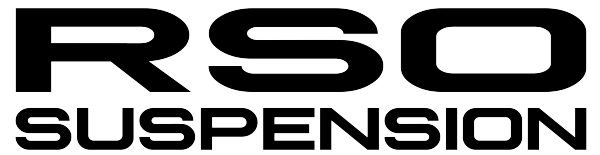

Components:

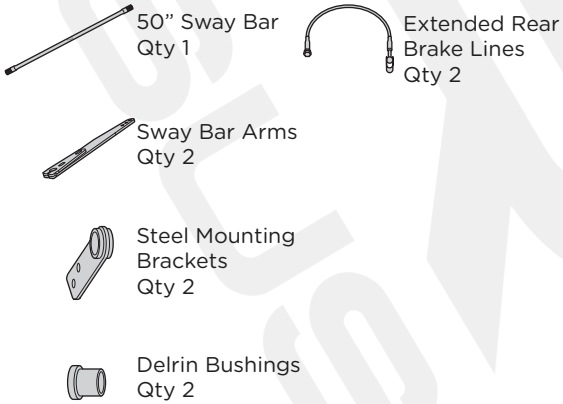

Hardware:

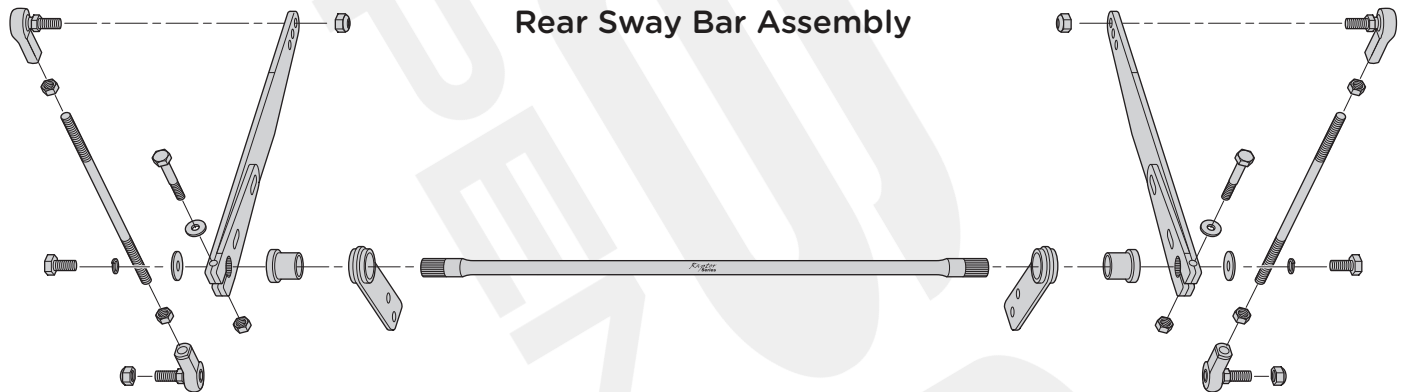
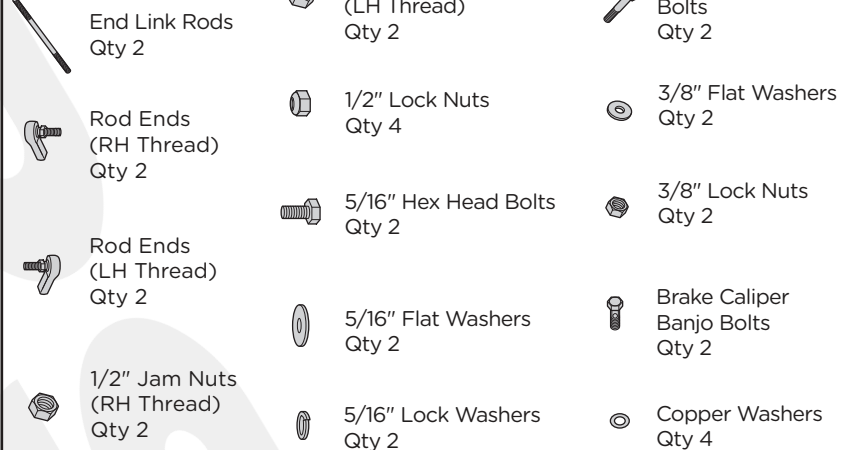

Tools Required:

- Hydraulic Jack/Jack Stands
- 1/2" Socket/Wrench
- 9/16" Socket/Wrench
- 9/16" Open-End Wrench
- 5/8" Socket/Wrench
- 11/16" Open-End Wrench
- 3/4" Socket/Wrench
- 3/4" Open-End Wrench
- Socket Wrench Extension
- Rubber Mallet/Dead Blow Hammer
- Electric Drill
- 1/8"-5/8" Drill Bit Set
- Torque Wrench

Safety Warning:

Aftermarket suspension systems or components may cause your vehicle to handle differently than it would with factory components. Please use caution to prevent loss of control or vehicle rollover during quick sharp turns and other sudden maneuvers. Thoroughly inspect vehicle suspension and components before and after every off-road use.

RSO Suspension recommends the use of your Factory Service Manual for disassembly and assembly of factory and related components. Tighten all bolts and hardware to factory torque specifications unless otherwise specified in this instruction.

INSTRUCTIONS:

1. Remove Factory Rear Sway Bar

Begin by raising and supporting the vehicle using a hydraulic jack and jack stands.

Once the vehicle is supported, disconnect the factory sway bar end links from the rear axle using a 3/4" Socket/Wrench and 3/4" Open-End Wrench.

Next, remove the two bolts connecting the sway bar mounting brackets to the frame on each side of the vehicle using a 5/8" Socket/Wrench and Socket Wrench Extension. Retain these bolts to be used for installation.

Once these bolts have been removed, you may remove the factory sway bar assembly from the vehicle.

2. Remove/Install Brake Lines

Begin by drilling a 5/8" hole in rear shock tower to relocate the brake lines to eliminate interference with the Sway Bar Arms. Start with a 1/8" bit and work your way up to 5/8" bit. See image for hole placement reference.

Remove the factory brake lines from the factory hard line and the brake caliper and carefully straighten the factory hard line so the fitting will reach to the 5/8" hole that was drilled. Use caution to prevent a kink in the factory hard line.

Install the supplied Extended Rear Brake Lines to the factory hard line meeting at the 5/8" hole that was drilled. Next, secure the Extended Rear Brake Lines to the brake calipers. Be sure to use supplied Brake Caliper Banjo Bolts with a Copper Washer on each side of the brake line fitting. Torque to 23 ft lbs.

Before driving, you must bleed the brake lines and ensure there is no interference with the newly installed Extended Brake Lines.

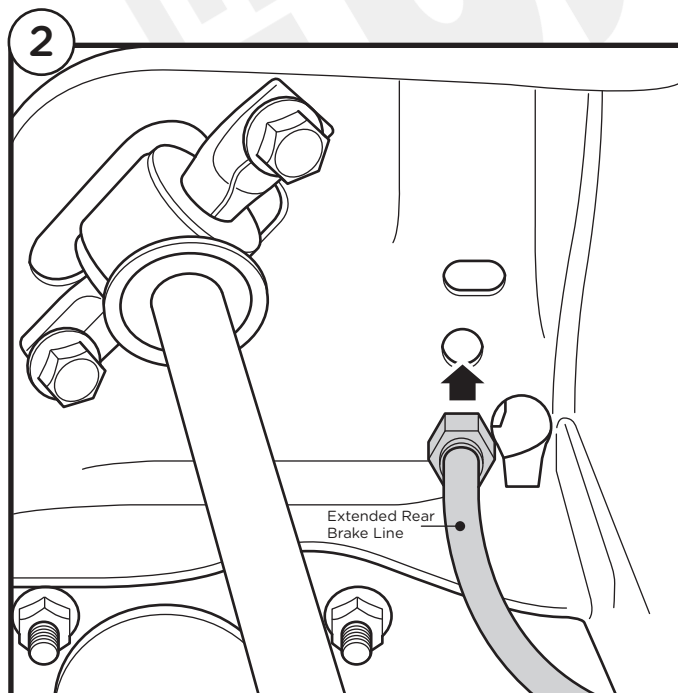

3. Install Rear Sway Bar

Begin by removing the two bolts connecting the bumper support to the frame using 5/8" Socket/Wrench. Retain these bolts to be used for installation. (3a)

Next, insert the Delrin Bushings into the bushing sleeve in the Steel Mounting Brackets. You may need to use a rubber mallet or dead blow hammer to fully seat these bushings. (3b)

Slide the 50" Sway Bar on top of the frame in between the body and the muffler from one side of the vehicle and extend to the opposite side.

You may now slide the Delrin Bushings and Steel Mounting Brackets over the splines of the 50" Sway Bar on each side. You may need to use a rubber mallet or dead blow hammer to get the splines to pass through the Delrin Bushings. Make sure that the splines are protruding evenly on both sides. (3c)

Now you will bolt the Steel Mounting Brackets to the frame using the factory bumper support hardware with a 5/8" Socket/Wrench. Note that the welded side of the bushing sleeve will be towards the inside of the vehicle and the Steel Mounting Brackets should be leaning towards the front of the vehicle. (3b)

If the bumper on your vehicle is using the same mounting holes as we intend you to mount the Steel Mounting Brackets, you will need to trim off the outside tube of the bushing sleeve to be flush with the face of the Steel Mounting Brackets. The Steel Mounting Bracket will then be installed on the outside of the existing bumper mount.

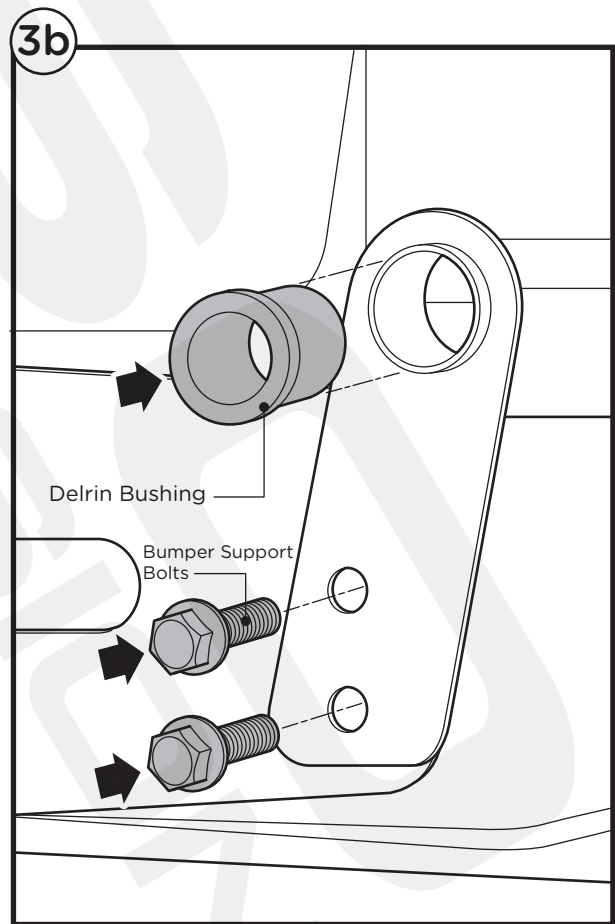
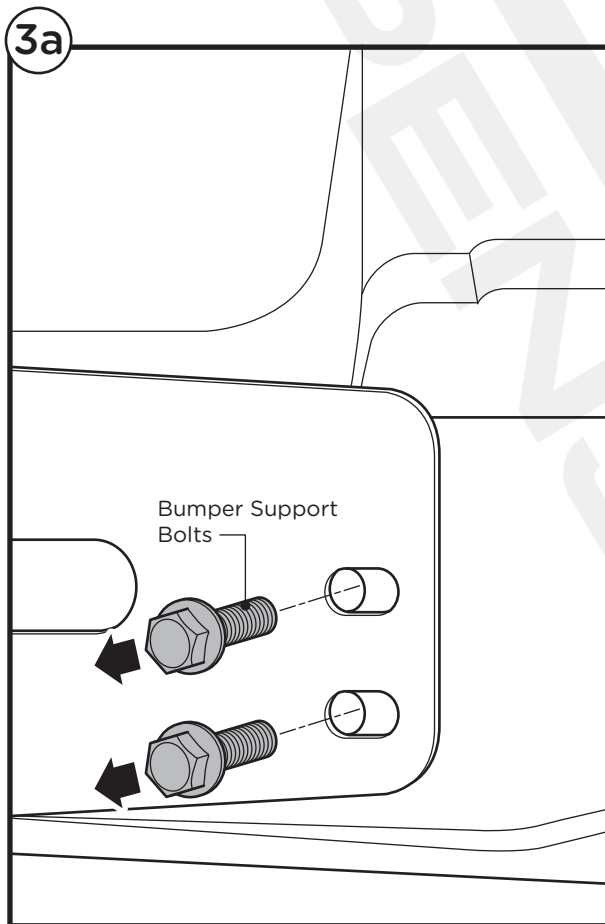

Slide the Sway Bar Arms over the protruding splines on the Sway Bar making sure that the Arms are "clocked" to the same position on each side. It may be necessary to clearance the body support to prevent the back of the Sway Bar Arms from making contact with body support. (3d)

With a 1/2" Socket/Wrench, fasten the Sway Bar Arms to the Sway Bar using one (1) 5/16" Hex Head Bolt, one (1) 5/16" Lock Washer and one (1) 5/16" Flat Washer per side.

Using a 9/16" Socket/Wrench and a 9/16" Open-End Wrench, tighten the pinch sleeve on the end of the Sway Bar Arms to ensure that the splines won't slip on the Sway Bar by using one (1) 3/8" Hex Head Bolt, one (1) 3/8" Flat Washer and one (1) 3/8" Lock Nut,

Rotate the the Sway Bar Arms prior to connecting the end links to make sure there is no interference.

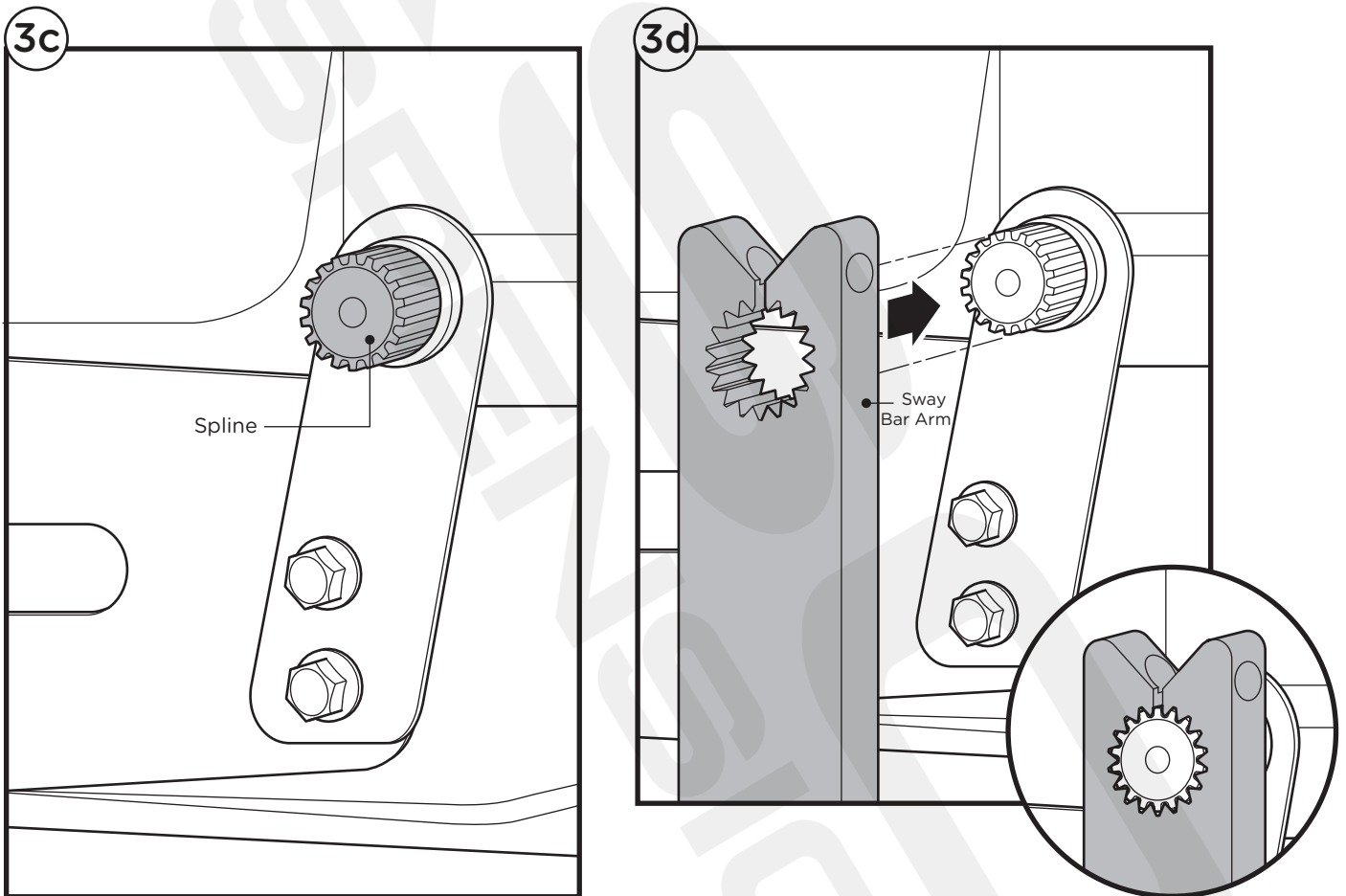

4. Connect Sway Bar End Links

To correctly adjust the Sway Bar End Links, the vehicle will need to be raised to where the axle assembly is in the middle of its travel.

Once the axle assembly is supported in the middle of its travel, rotate the Sway Bar Arms to where they are at a 0 degree angle or as close to horizontal as possible.

Turn the Sway Bar Rod Ends to adjust the length of the End Links to match the distance between the mounting points on the Sway Bar Arms and the axle mount.

There are three mounting locations on the Sway Bar Arms to attach the end links. Using the first mounting point closest the end of the arm will offer the lowest resistance with the most flex. Resistance and stiffness will be increased as you move to the second and third mounting locations.

Fasten the Rod Ends to each mounting point using one (1) 1/2" Lock Nut on each Rod End. Hold the Rod End stud to keep from spinning with a 9/16" Open End-Wrench and tighten the 1/2" Lock Nut with a 3/4" Socket/Wrench.

The final step of this installation is to tighten the 1/2" Jam Nuts on the Sway Bar End Link Rod using a 3/4" Open-End Wrench.

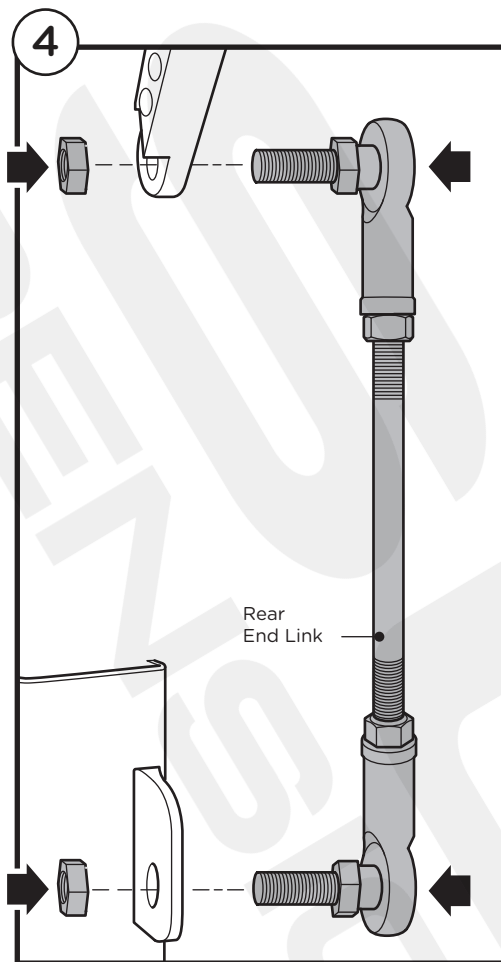

5. Post Installation

Upon completion of installation and within 50 miles of driving, it is necessary to check and ensure all hardware is properly torqued to factory specifications as noted in the factory service manual or as specified in this instruction.