

### INSTALLATION NOTES

PROFESSIONAL INSTALLATION IS STRONGLY RECOMMENDED!

If you intend to do this installation yourself, please use extreme caution when working under a vehicle that is supported with jack stands. Serious injury or death can occur.

Read through entire installation manual to ensure that you understand all of the steps before proceeding with installation. If these instructions are not properly followed, severe frame, suspension, and tire damage may occur. Product failure or vehicle damage caused by improper installation will not be covered under warranty!

Remove all contents from the package and inspect for any damage. Also, verify that all components listed are included before you begin installation. If anything is missing or damaged please contact us at [customerservice@cyc-engineering.com](mailto:customerservice@cyc-engineering.com) - IMPORTANT: DO NOT INSTALL DAMAGED PARTS!

### COMPONENTS

Qty 2: Adjustable Front Upper Control Arms

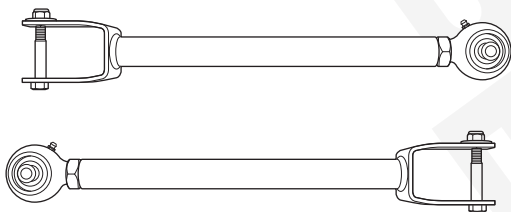

### TOOLS REQUIRED



Jack Stands

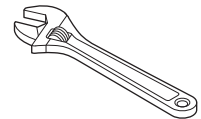

Adjustable Wrench

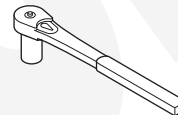

10mm, 21mm Socket

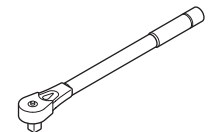

Torque Wrench



Jack

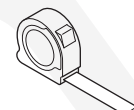

Tape Measure

# ADJUSTABLE FRONT UPPER CONTROL ARMS

SKU# 170107-459801

# RSO SUSPENSION

1. Chock your rear tires and then raise the front tires off the ground using a properly rated jack and jack stands. Ensure the vehicle is properly supported then remove the front tires.

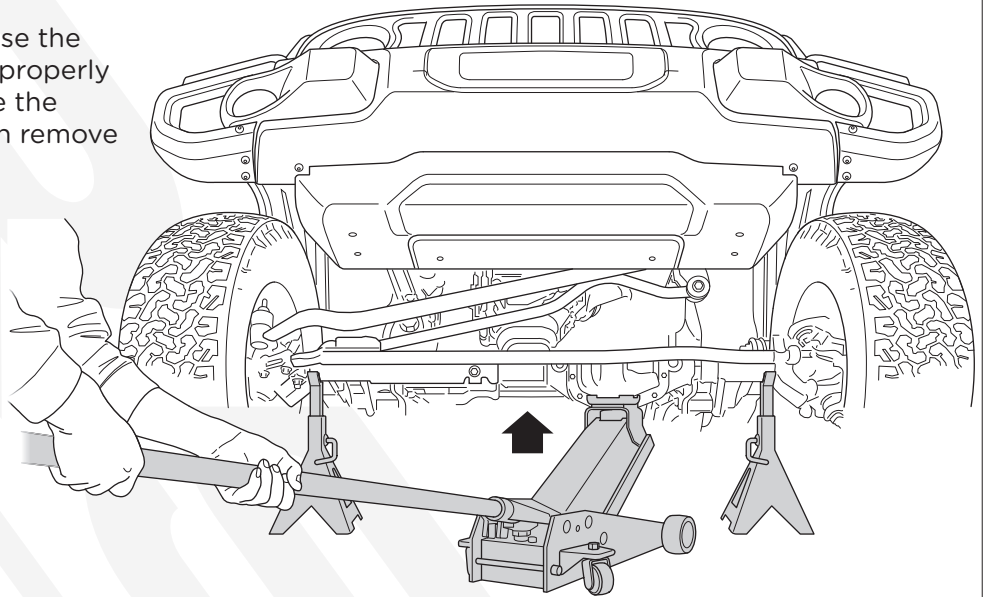

2. Use a hydraulic jack to raise the axle and remove any tension on the front suspension. Remove any electrical connections clipped onto the upper control arm clevis if equipped. Use a 10mm socket to remove the heat shields covering the upper control arm to frame side mounts, retain the heat shields and hardware as they will be reused during installation. Use a 21mm socket to remove the factory bolt on the frame and axle side mounts.. Notate the orientation of the factory upper control arm hardware as it will be reused for installation of the RSO Front Upper Control Arms.

3. Before placing control arms in mounting position, you'll need to adjust them to our suggested base length. For 2.5" Lifts we recommend 19" & For 4" Lift we recommend 19.5". Leave the jam nut loose and place the RSO control arms into the axle side and frame side control arm mounts. Loosely attach the factory hardware but do not torque down until all adjustments are completed.

4. The Adjustable Front Upper Control Arms should be positioned to where the flat side of the fork that attaches to the axle mount is facing down and the sloped side facing up. Hand tighten the original hardware to mount each end of the control arms. Once both control arms have been properly installed, lower the vehicle to the ground until the coil springs are supporting the full weight of the vehicle. Hand tighten the factory control arm mounting bolts and do not torque until all adjustments are final.

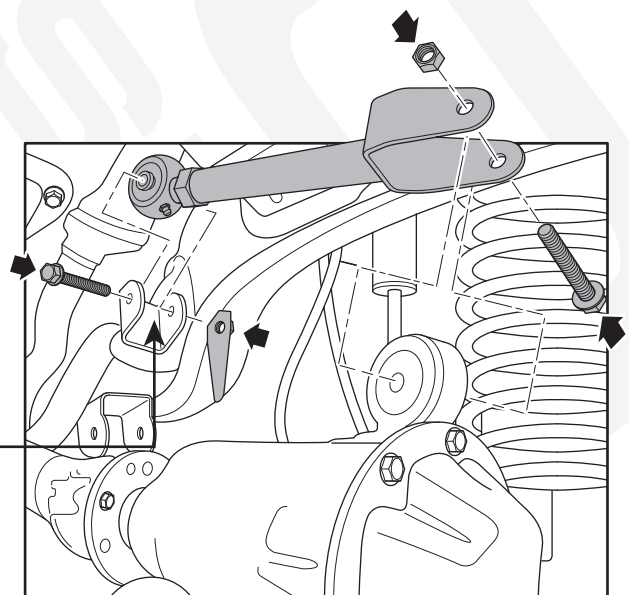
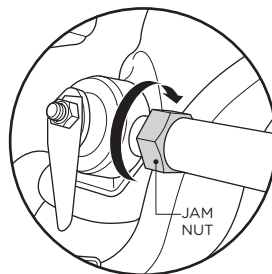

## ADJUSTABLE FRONT UPPER CONTROL ARMS

SKU# 170107-459801

**RSO**  
SUSPENSION

5. Measure both sides of the vehicle to ensure the axle position matches. Measure the caster angle to ensure it is within factory specs, you can adjust the length of the control arms to get more or less caster angle. We recommend setting the caster between 4-5 degrees for optimal driving experience. Once you have determined caster and axle position are within spec, tighten the jam nut using a large adjustable wrench and torque to 55ft/lbs. With the vehicle still on the ground supporting it's own weight use a 21mm socket and wrench to torque the frame and axle side hardware to 75ft/lbs. Clip the electrical harness back onto the control arm clevis if equipped. Reinstall the heat shields over the frame side mounts of the upper controls arms and torque to 40 in/lbs.
6. We now recommend a professional alignment. Check all hardware after 100 miles of driving and retorquer as necessary.

## **REGULAR MAINTENANCE SCHEDULE**

Control Arms are serviceable, however the ball and socket joints are a consumable component. See Signs of Wear below for more information.

For the ball and socket joints, a visual inspection at every oil change is recommended to detect any accumulation of dirt, debris or moisture.

## **CLEANING & LUBRICATION**

Should dirt accumulate on the ball or race, wipe clean with a rag.

We recommend regreasing the joints every 10,000 miles.

## **SIGNS OF WEAR**

Excessive back and forth play or rattling in the joints indicates wear. In such instances, it is imperative to replace the affected parts promptly. You can order replacement parts at [www.cyc-engineering.com](http://www.cyc-engineering.com)

Replacement Part numbers for this particular SKU are listed below for your reference.

SKU: REP-BNSJOINT-1-KIT (Replacement Ball & Socket Joints)

## **TECHNICAL NOTES**