

INSTALLATION NOTES

PROFESSIONAL INSTALLATION IS STRONGLY RECOMMENDED!

If you intend to do this installation yourself, please use extreme caution when working under a vehicle that is supported with jack stands. Serious injury or death can occur.

Read through entire installation manual to ensure that you understand all of the steps before proceeding with installation. If these instructions are not properly followed, severe frame, suspension, and tire damage may occur. Product failure or vehicle damage caused by improper installation will not be covered under warranty!

Remove all contents from the package and inspect for any damage. Also, verify that all components listed are included before you begin installation. If anything is missing or damaged please contact us at customerservice@cyc-engineering.com - IMPORTANT: DO NOT INSTALL DAMAGED PARTS!

COMPONENTS

Qty 2: Adjustable Rear Upper Control Arms

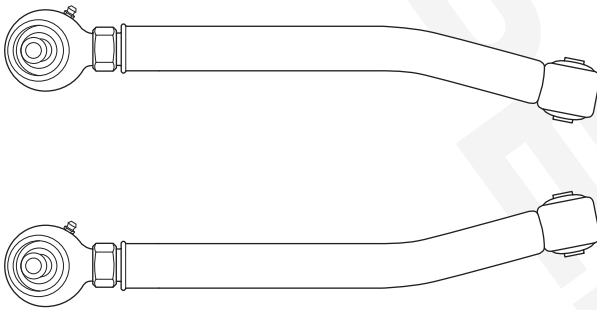

TOOLS REQUIRED



Jack Stands

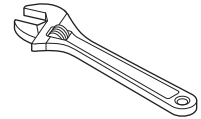

Adjustable Wrench

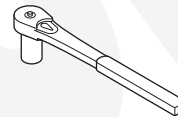

18mm Socket

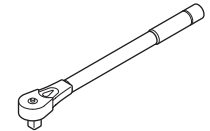

Torque Wrench

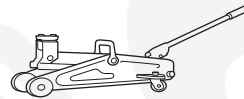

Jack

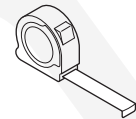

Tape Measure

ADJUSTABLE REAR UPPER CONTROL ARMS

SKU# 170107-459803

RSO SUSPENSION

1. Chock your front tires and then raise the rear tires off the ground using a properly rated jack and jack stands. Ensure the vehicle is properly supported then remove the rear tires.

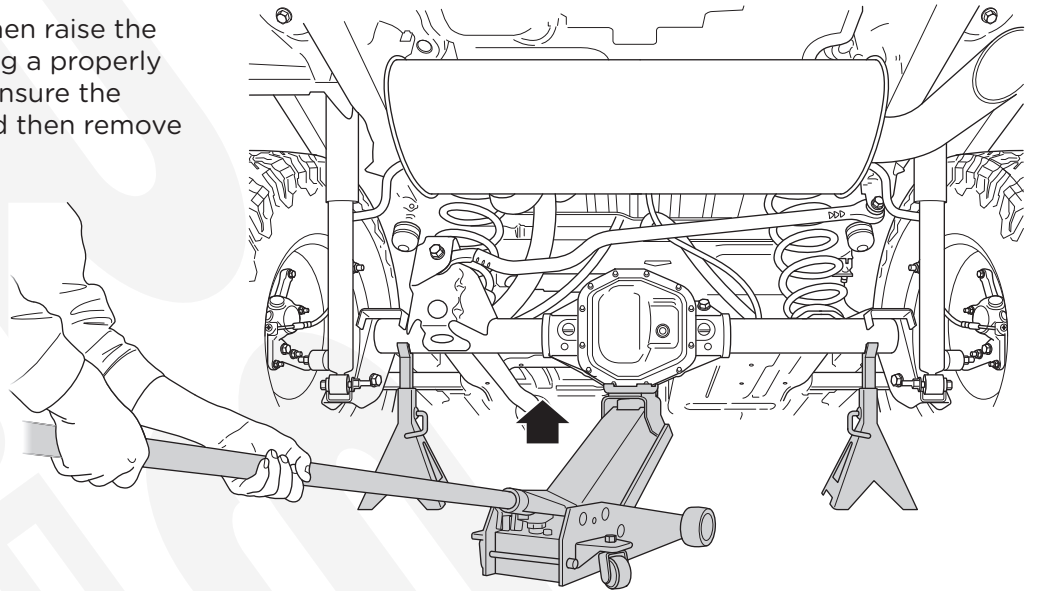

2. Use a hydraulic jack to raise the axle and remove any tension on the rear suspension. Use a 18mm socket to remove the factory hardware from the axle side and frame side of the control arm mounts. Retain the factory hardware as it will be reused for installation of the new RSO Adjustable Rear Upper Control Arms.

3. Before placing control arms in mounting position, you'll need to adjust them to our suggested base length. For 2.5" and 4" Lifts we recommend 18.5". Leave the jam nut loose and place the RSO control arms into the axle side and frame side control arm mounts. Loosely attached the factory hardware but do not torque down until all adjustments are completed.

4. The Adjustable Rear Upper Control Arms should be positioned to where the bend in the arm goes towards the inside of the vehicle. The fixed end will mount to the axle while the adjustable end will be attached to the frame mount. Hand tighten the original hardware to mount each end of the control arms. Once both control arms have been properly installed, lower the vehicle to the ground until the coil springs are supporting the full weight of the vehicle. Hand tighten the factory control arm mounting bolts and do not torque until all adjustments are final.

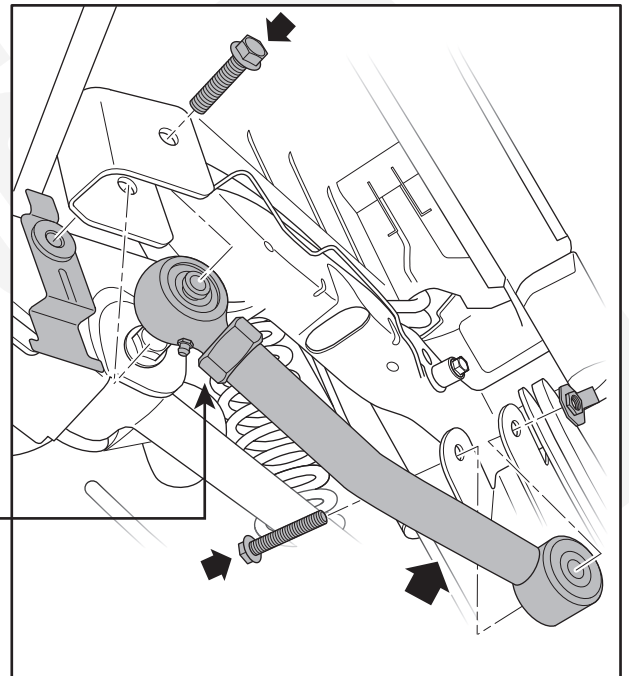
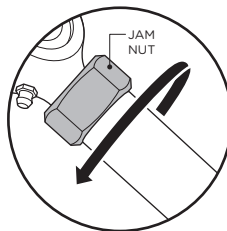

ADJUSTABLE REAR UPPER CONTROL ARMS

SKU# 170107-459803

RSO
SUSPENSION

5. Measure both sides of the vehicle to ensure the axle position matches. Measure the caster and pinion angle to ensure it is within factory specs, you can adjust the length of the control arms to get more or less caster and pinion angle as well as centering the axle in the wheel well. Once you have determined caster, pinion angle and axle position are within spec, tighten the jam nut using a large adjustable wrench and torque to 55ft/lbs. With the vehicle still on the ground supporting it's own weight use a 18mm socket and wrench to torque the frame side and axle side hardware to 125ft/lbs.
6. We now recommend a professional alignment. Check all hardware after 100 miles of driving and retorque as necessary.

REGULAR MAINTENANCE SCHEDULE

Control Arms are essentially maintenance free, however the bushings and the ball and socket joints are a consumable component. See Signs of Wear below for more information.

For the bushings, a visual inspection at every oil change is recommended to detect any accumulation of dirt or debris.

For the ball and socket joints, a visual inspection at every oil change is recommended to detect any accumulation of dirt, debris or moisture.

CLEANING & LUBRICATION

Should dirt accumulate on the bushings, wipe clean with a rag.

We recommend regreasing the joints every 10,000 miles.

SIGNS OF WEAR

Excessive back and forth play or rattling in the bushings and/or joints indicates wear. In such instances, it is imperative to replace the affected parts promptly. You can order replacement parts at www.cyc-engineering.com

Replacement Part numbers for this particular SKU are listed below for your reference.

SKU: REP-BUSHING-9-KIT (Replacement Rubber Bushings)

SKU: REP-BNSJOINT-3-KIT (Replacement Ball & Socket Joints)

TECHNICAL NOTES