

REAR RING & PINION



General Notes:

Gear installation and setup should be performed by an individual who is experienced with gear and axle set up. The following tools are required for proper gear set up:

- Micrometer or calipers
- Bearing splitter and press
- Socket wrench and sockets
- Housing spreader
- Dial indicator with magnetic base
- Brass tipped hammer and drift

1. Securely support the vehicle on jack stands or automotive lift and remove wheels.

2. Using a 18mm socket, remove the bolts that secure the brake caliper mounting bracket. Remove the brake calipers and rotors. If necessary, tie back the brake calipers to the frame so they do not obstruct your work.

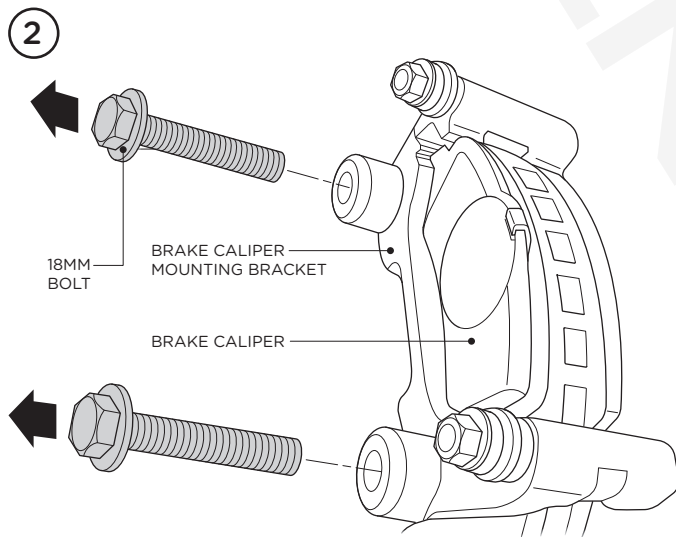

3. Remove the parking brake cables from the support plate.

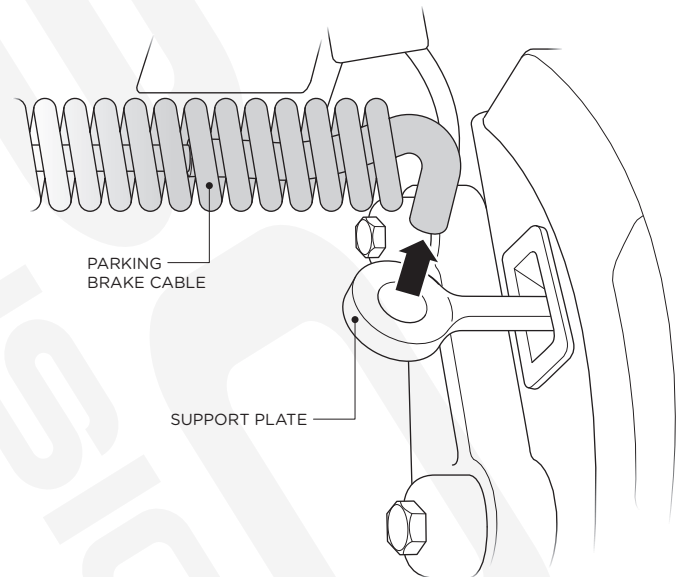

4. Using an 8mm socket, remove the ABS sensor from the support plate

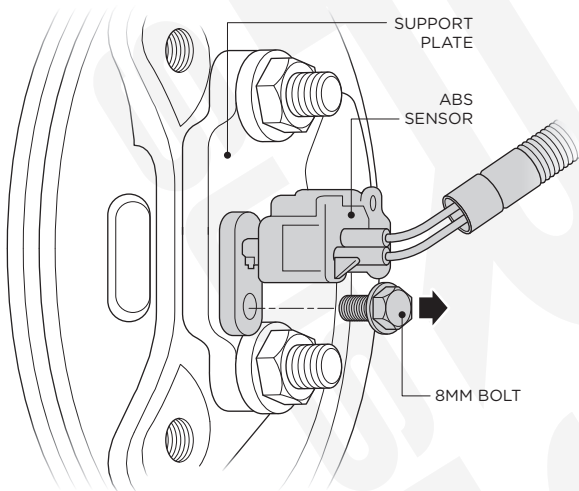

5. Using an 18mm socket, remove the four (4) axle retainer plate nuts so you can remove the axle shafts.

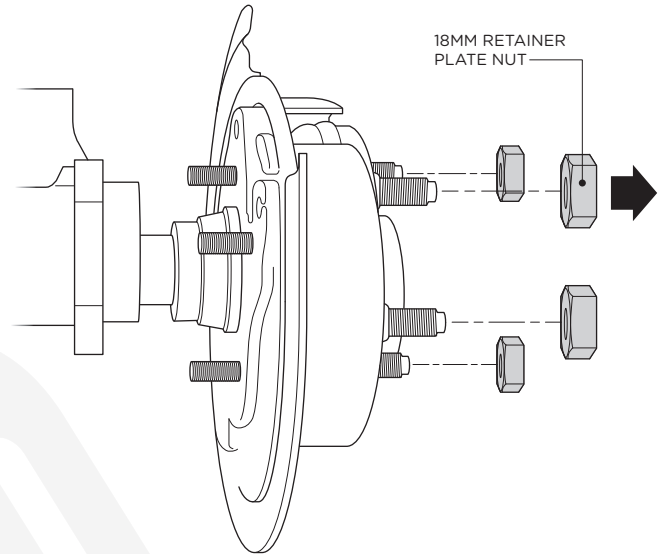

6. Drain the differential, then remove the differential cover.

7. Locate the driveshaft and remove it from the rear pinion yoke.

8. Remove bolt securing the diff lock chassis. Remove the diff lock chassis harness from the bulkhead connector (8a), then remove the diff lock sensor from the chassis harness (8b).

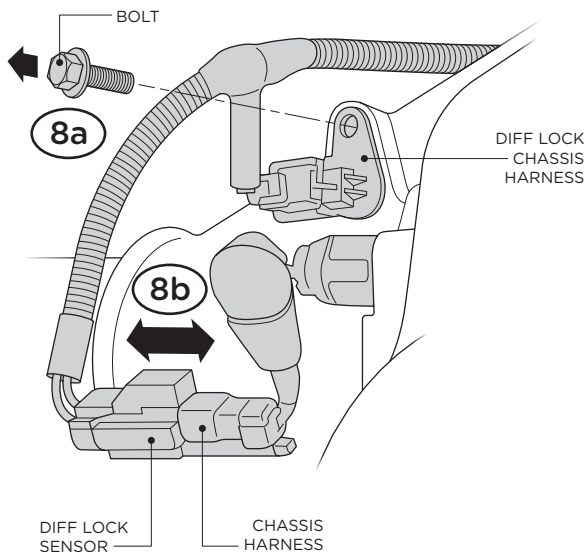

9. Using an 8mm socket, remove the diff lock bulkhead connector. Pull the connector from the housing and disconnect the locker coil wires from the bulkhead connector.

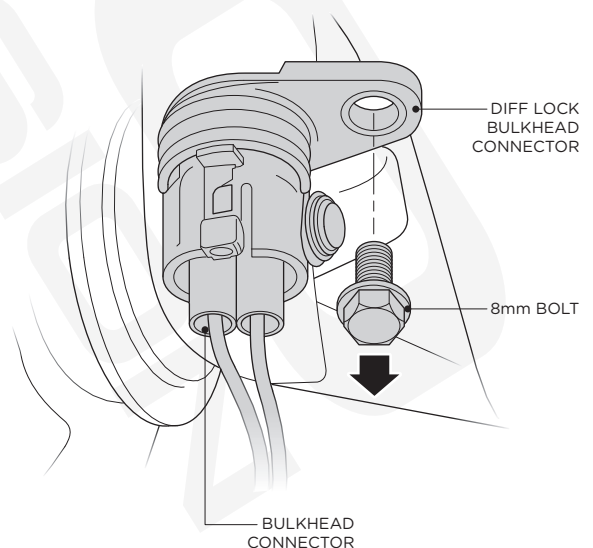

10. The differential bearing caps must be removed. The differential bearing caps are matched to the side they came from. There should be a matching horizontal and vertical letters stamped on the bearing cap and the adjacent diff cover mounting surface. If they are not marked, mark them now.

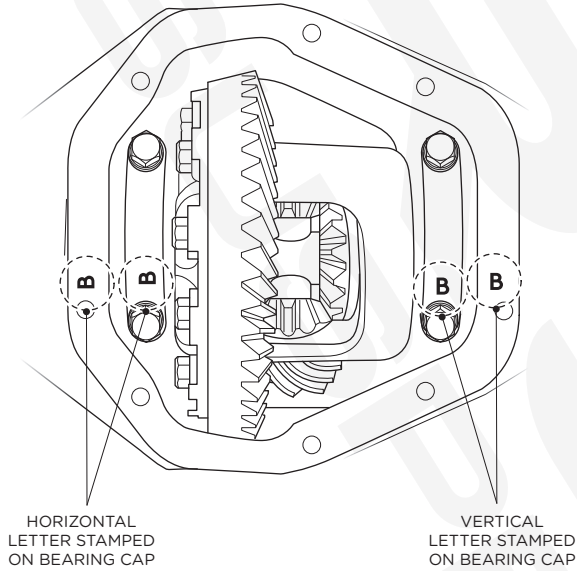

11. Using a 3/4" socket (11a), loosen and remove four (4) differential bearing cap bolts (11b) to remove the two (2) differential bearing caps.

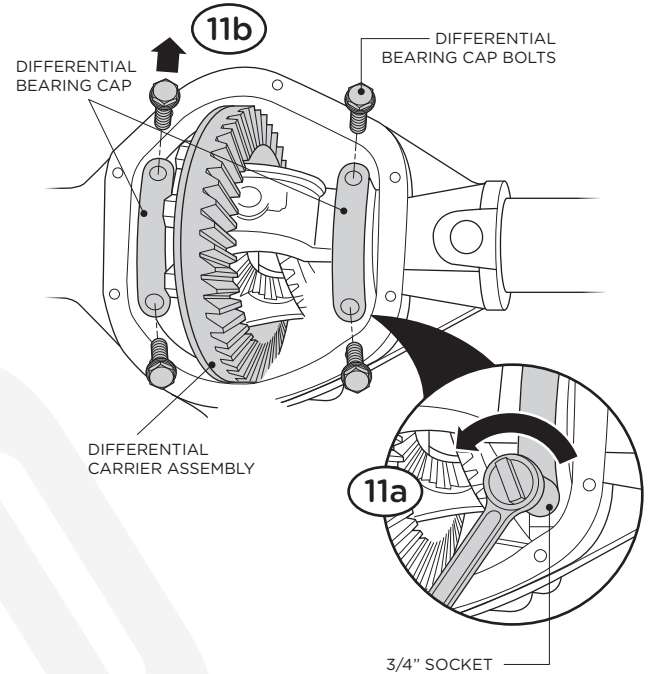

12. Remove the differential carrier assembly. Keep track of which side the carrier bearing races and shims came from. The bearing races must be installed on the side they were originally located.

Measure and record the thickness of each shim in the diff set-up sheet. The sum of these two (2) shims will be the total shim thickness needed for the carrier bearings.

Keep the total shim thickness for your backlash adjustments and final carrier installation.

13. Using a 3/4" wrench (13a), remove the locker indicator sensor from the housing (13b).

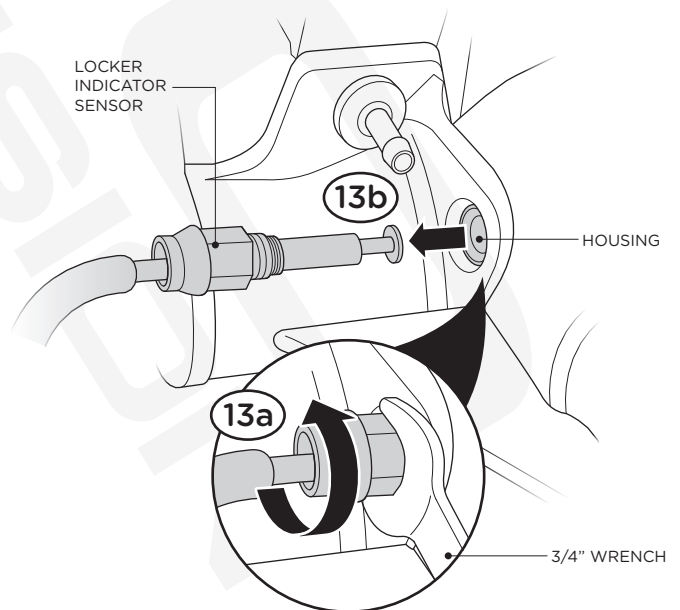

14. Use an in-lb dial or beam type torque wrench to measure the pinion bearing torque to rotate. The torque to rotate should be in the 10-20 in-lb range. Record this number in the diff set-up sheet for future installation if you are using the original pinion bearings.

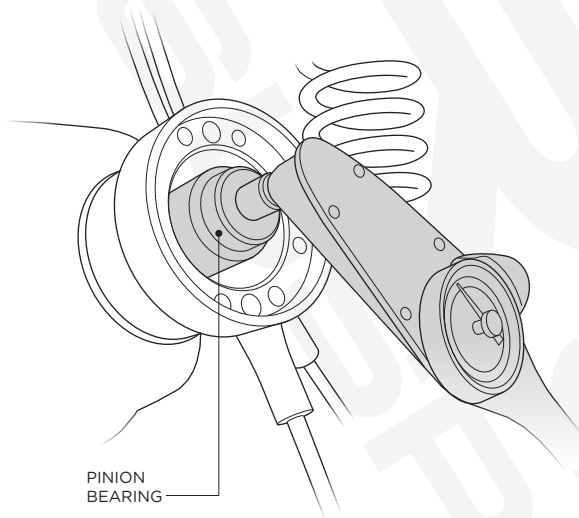

15. Using a 1-5/16" socket, remove the pinion yoke nut. Next, use a hammer or punch and tap the end of the pinion shaft to remove it from the housing. Make sure the crush sleeve comes out with the pinion gear.

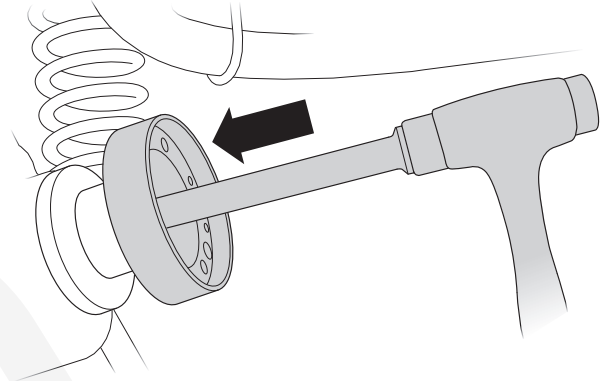

16. Carefully inspect all the bearings for any sign of abnormal wear. The bearings may be reused if this is a low mileage gear swap and if the bearings are in good condition.

Be careful as you remove and install the pinion and yoke. You do not need to remove the pinion seal and outer pinion bearing if you are not replacing them.

Now is a good time to replace the bearings if needed. The carrier bearings are quite difficult to remove. Removal requires a special bearing puller. If replacing the pinion bearings, remove the pinion seal and change the bearing races in the housing. Do not install new pinion seal in until final assembly.

17. Using a 13/16" socket, remove the ring gear bolts. The ring gear should have a light press fit on the carrier. Thread a few of the bolts in the ring and tap the bolts so you can remove the ring gear. Be careful to not let the ring gear fall on the coil or wires for the locker.

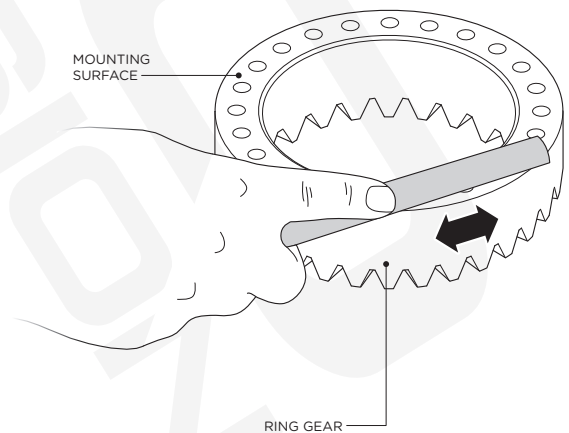

18. Carefully clean the ring mounting surface of the carrier and new ring gear.

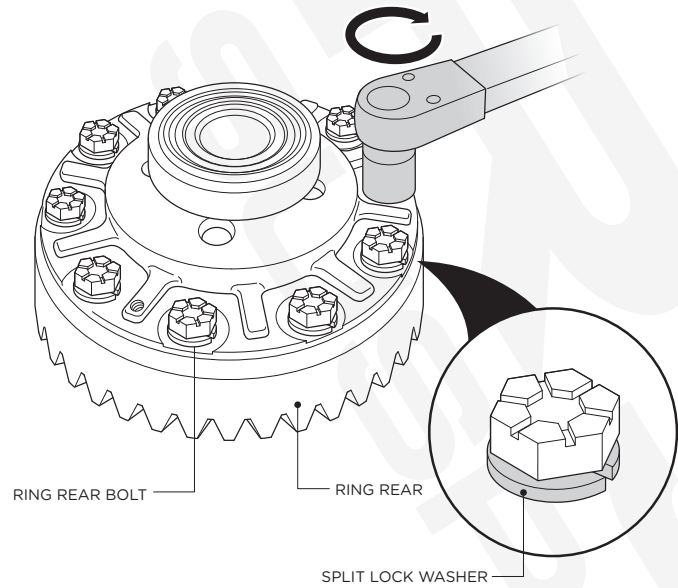

19. Run a fine file or sand paper over the mounting surface to remove any burrs or high spots.

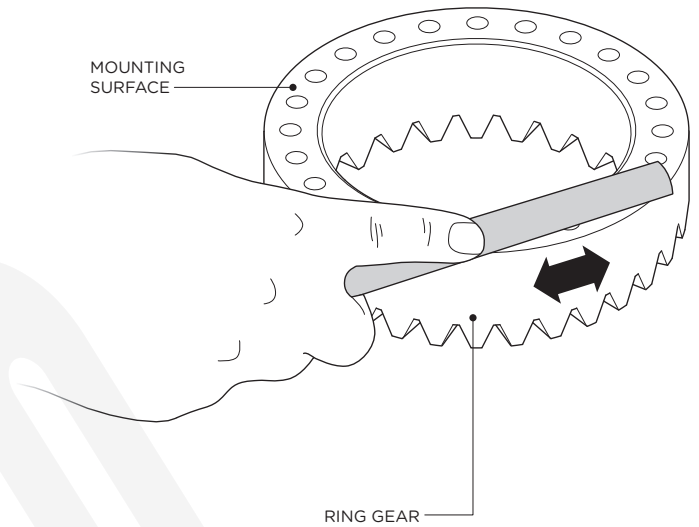

20. Clean the threaded holes in the ring gear and ring gear bolts with brake or carb cleaner. Early JK's used 7/16" ring gear bolts and the later JK's use 1/2" ring gear bolts. The ring is tapped for both.

Place a small amount of thread locker onto the first few threads of each ring gear bolt. Use only the new ring gear bolts. Do not use the used ring gear bolts. Place the new ring gear on the carrier. Torque the 1/2" bolts to 100 ft-lbs or 7/16" bolts to 65 ft-lbs.

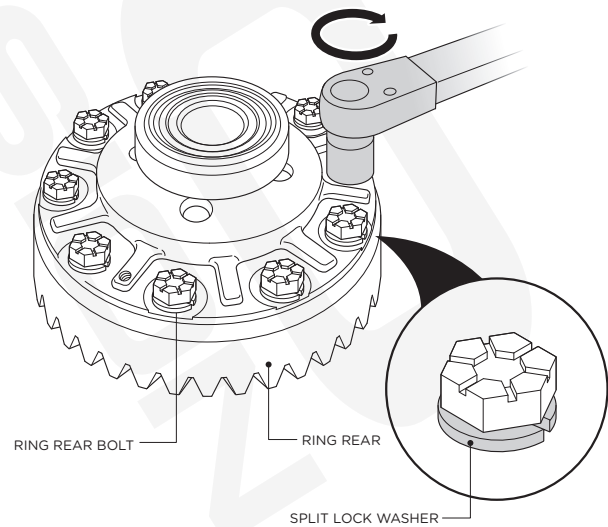

21. Remove the inner pinion bearing from the pinion gear. This bearing will be re-used if you are not changing the bearings.

The easiest way is to use a bearing splitter and a press. The pinion depth shim is between the bearing and pinion gear. Save this shim and record the thickness in the gear set-up sheet. You will use it on the new gears.

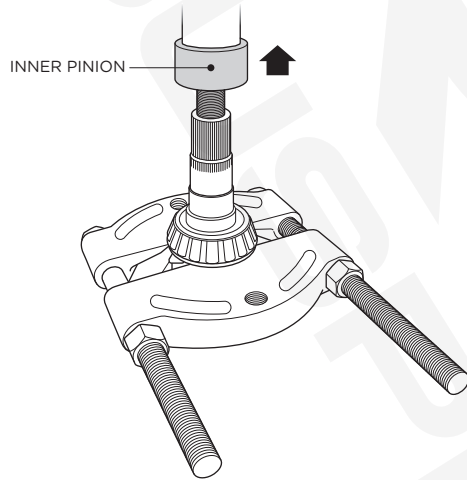

22. Install the original pinion shim on the new pinion gear and press on the original pinion bearing.

If re-using or new bearing is using new bearings. A piece 2" x .120 wall tube works well for this.

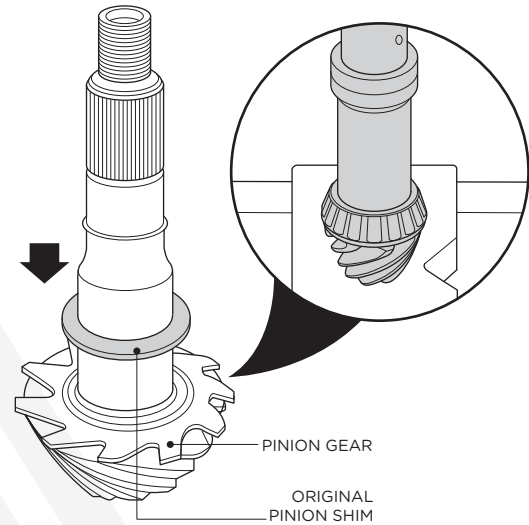

23. Place a small amount of grease onto the outer pinion bearing surface and splines of the new pinion gear, then install the pinion into the axle housing without a crush sleeve.

Next, slide the pinion yoke onto the pinion shaft splines and tap the pinion yoke with a brass hammer. This will seat the outer pinion bearing onto the pinion shaft until enough threads are showing so you can start a pinion nut. Be careful not to damage the pinion seal.

Use the original pinion nut (until the final pinion assembly) with the new pinion nut and new crush sleeve. Tighten the pinion nut to achieve 10-20 in-lbs of torque to turn.

24. Install the carrier assembly into the diff housing. Use the original carrier shims and swap them from side to side to get a baseline for the gear backlash. Make sure the carrier bearings and bearing caps are on the same side they were removed. Tighten the bearing caps to 80 ft-lbs.

24. Check the gear backlash with a dial indicator. Try to align the indicator (as perpendicular as you can) to the drive side of the gears. Gear backlash should be in the .006-.010" range. Note that .008" is preferred.

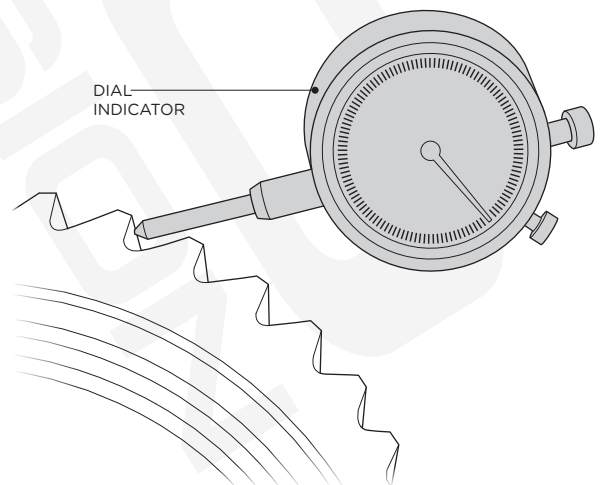

25. Adjust the thickness of the carrier shims to get the desired amount of backlash. The total carrier shim thickness should remain the same as the original shims. Whatever you take from one side, you need to add to the other side.

A rough rule of thumb to change the carrier shim thickness is a 1.5:1 ratio of the amount of backlash you want to change. For example, if you want to change the backlash by .004", shim the carrier over by .006. Record each trial set up in the diff set-up sheet so you can keep track of all your measurements and results.

27

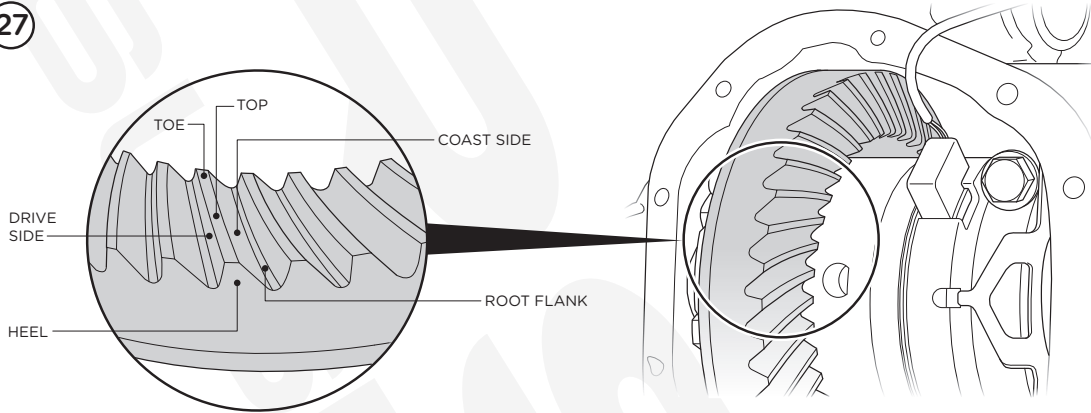

Acceptable Patterns

Pinion is too Shallow

Pinion is too Deep

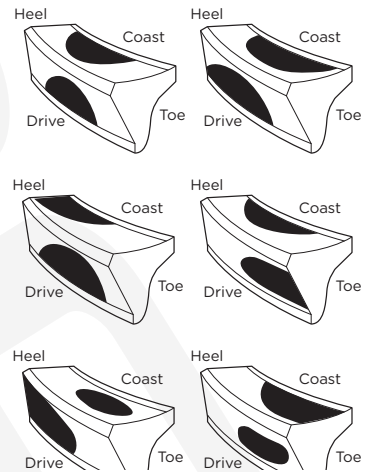
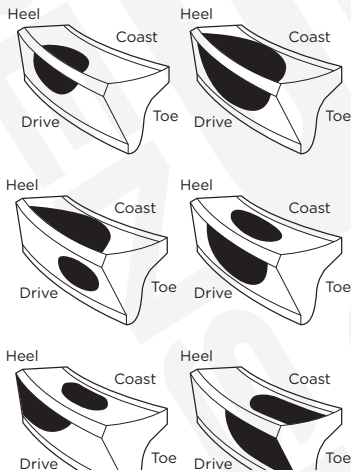
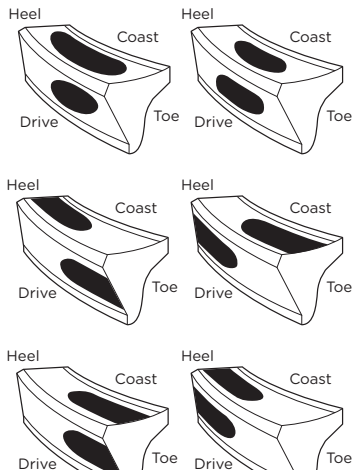

26. Once you have the backlash in spec, use the gear marking compound to check the gear mesh pattern. Paint about four (4) teeth on both the coast side and the drive side.

Place some drag on the carrier by pressing on it with your hand and a rag. Turn the pinion gear so the painted teeth run across the pinion in both directions. Do this a few times.

The gear mesh pattern will be the best indicator that the gear is set up and it will show you what adjustments you may still need to make to the pinion shim.

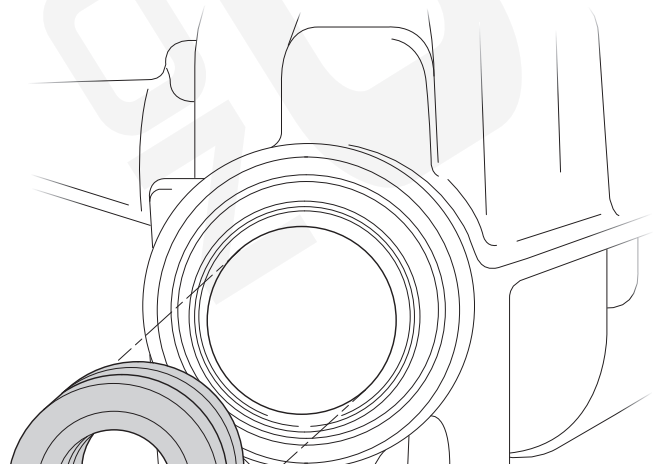

27. Next, you must read the gear mesh contact pattern.

The gear mesh pattern reveal how to change the pinion shim. The backlash will not affect the gear mesh pattern much. Keep the backlash in spec.

Pay close attention to the contact pattern that occurs between the top of the gear tooth and the root. The contact pattern should be centered between the top and the root soft edges.

You will need to move the pinion closer to the ring gear if the contact pattern is heavy towards the top of the gear tooth. You can achieve this by adding pinion shim. The contact pattern will move toward the root while the drive side pattern will move toward the tow. The coast side will move toward the heel.

You will need to move the pinion away from the ring gear if the contact pattern is heavy towards the root of the gear. You can achieve this by subtracting the pinion shim. The contact pattern will move toward the top while the drive side pattern will move toward the heel. The coast side pattern will move toward the toe.

Ideal Contact Pattern

27

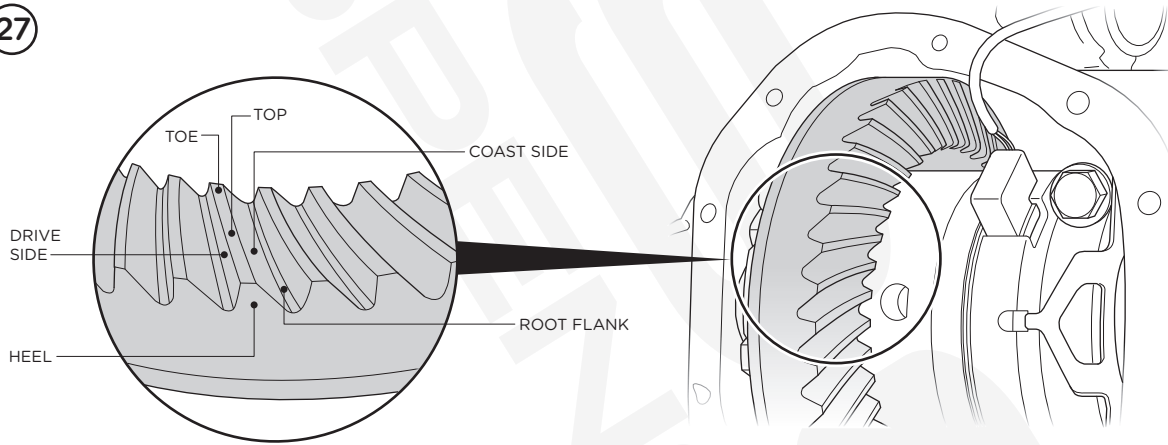

Acceptable Patterns

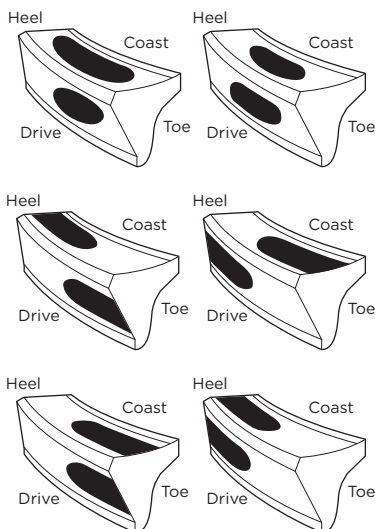

Pinion is too Shallow

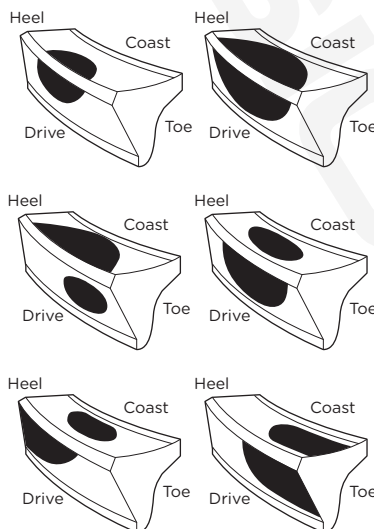

Pinion is too Deep

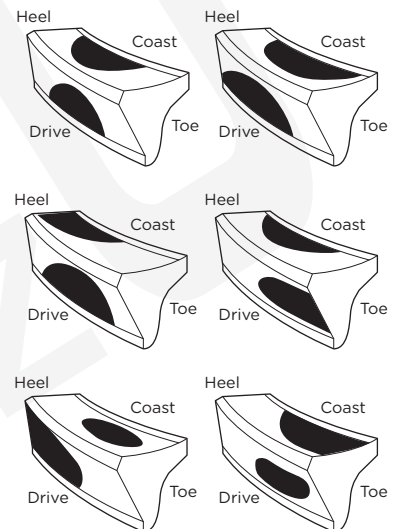

28. Once you have an acceptable contact pattern and backlash measurement, you may begin final gear assembly. Remove the carrier and pinion.

29. If you are replacing the pinion bearings and seal, make sure the new bearing races are installed in the housing. Place the oil slinger behind the outer pinion bearing (if used) and install the pinion seal.

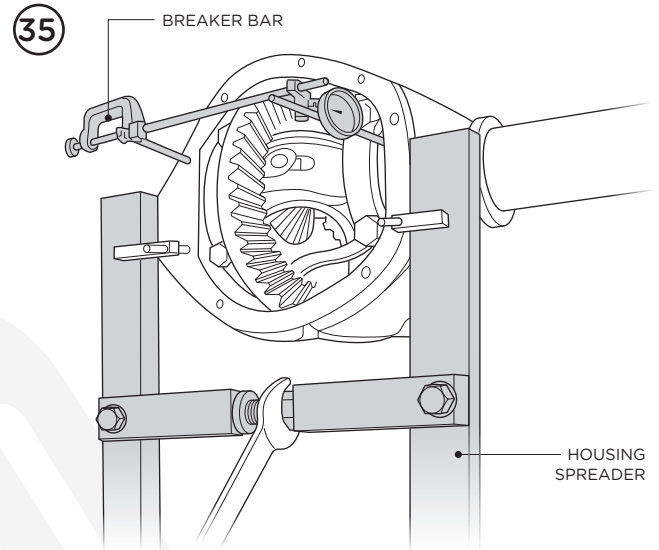

30. Clean the pinion splines and the inside of yoke with brake or carb cleaner. Apply some silicone sealer into the yoke splines near the pinion nut end. This will prevent gear oil from leaking through the splines in the yoke.

Apply fresh gear oil to the bearings and install the pinion and yoke using the new crush sleeve and new pinion nut. You will need to tighten the pinion nut to collapse the crush sleeve to obtain the correct amount of torque to turn the pinion. You can do this with an impact wrench or a long breaker bar and something to hold the pinion yoke. Be careful to not over-tighten the pinion nut. Overtightening can cause damage to the bearings. Damage will result in needing a new pinion nut and crush sleeve.

Tighten the pinion nut to remove end play from the bearings, then tighten a little at a time and check the torque to turn often. Turn the pinion a few times before taking torque to turn measurements to seat the bearings. If using the original bearings, tighten the pinion nut to get the original torque to turn value or 10-20 in-lbs. The result of using new bearings will require a torque to turn value of 20-40 in-lbs.

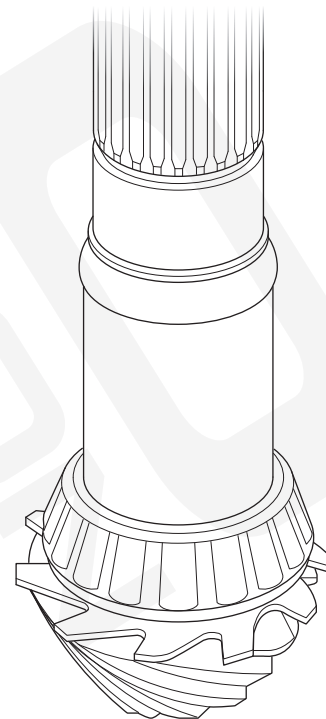

31. Install the locker indicator sensor. Use some Teflon thread sealant on the threads.

32. We recommend adding a little more carrier bearing pre-load than what was installed from the factory. Add about .002" to each side carrier bearing shims if you are using the old bearings or add .005" if using new bearings. You may need a housing spreader to install the carrier without damaging the thin shims.

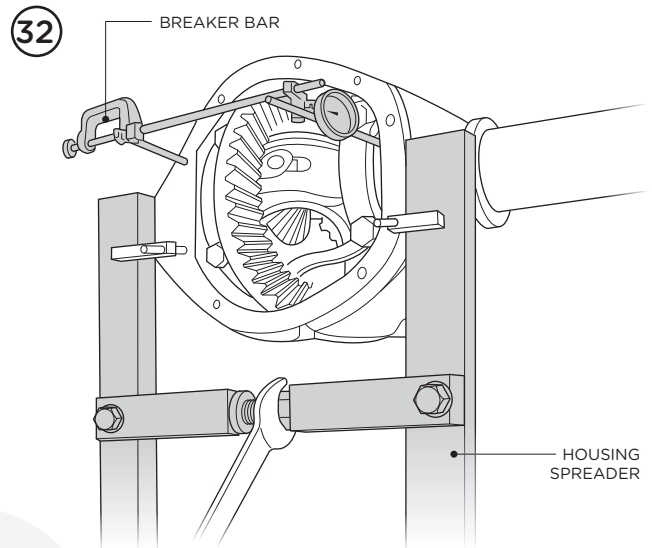

33. Install the carrier and torque the bearing cap bolts to 80 ft-lbs. There is a clearance section on the locker actuating coil to clear the locker indicator sensor. When the Anti-Rotation Bracket is aligned with the notch in the coil, the coil is in correct position. While tightening the bearing cap bolts, make sure the coil is aligned properly. If the coil is not aligned correctly, you will bend the locker indicator sensor and it will not operate properly. Make sure the head of the locker indicator sensor is on the inside of the locker engagement ring. The locker engagement ring moves toward the ring gear and pulls the locker indicator sensor out when engaged. If the lock is not installed correctly, the locker will be stuck on the lock position and will not unlock.

