

### INSTALLATION NOTES

PROFESSIONAL INSTALLATION IS STRONGLY RECOMMENDED!

If you intend to do this installation yourself, please use extreme caution when working under a vehicle that is supported with jack stands. Serious injury or death can occur.

Read through entire installation manual to ensure that you understand all of the steps before proceeding with installation. If these instructions are not properly followed, severe frame, suspension, and tire damage may occur. Product failure or vehicle damage caused by improper installation will not be covered under warranty!

Remove all contents from the package and inspect for any damage. Also, verify that all components listed are included before you begin installation. If anything is missing or damaged please contact us at [customerservice@cyc-engineering.com](mailto:customerservice@cyc-engineering.com) - IMPORTANT: DO NOT INSTALL DAMAGED PARTS!

### COMPONENTS

Qty 1: Forged Adjustable Front Track Bar

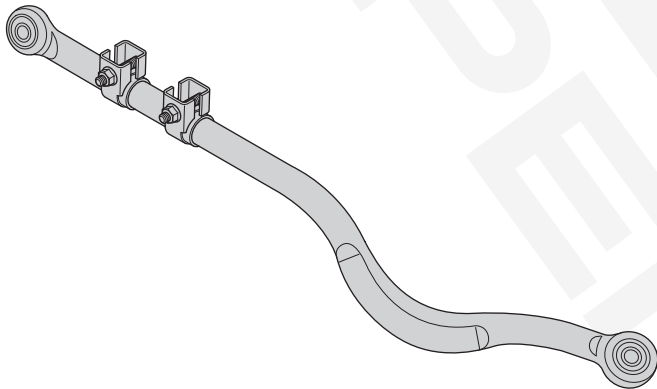

### TOOLS REQUIRED



Jack Stands

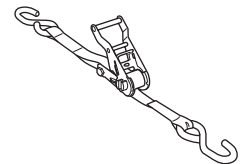

Ratchet Strap

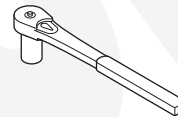

18mm, 21mm Socket

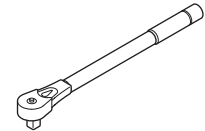

Torque Wrench

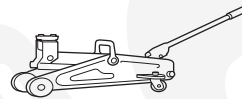

Jack

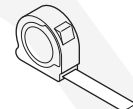

Tape Measure

# FORGED ADJUSTABLE FRONT TRACK BAR

SKU# 170118-441500

# RSO SUSPENSION

1. Chock your rear tires and then raise the front tires off the ground using a properly rated jack and jack stands. Ensure the vehicle is properly supported then remove the front tires.

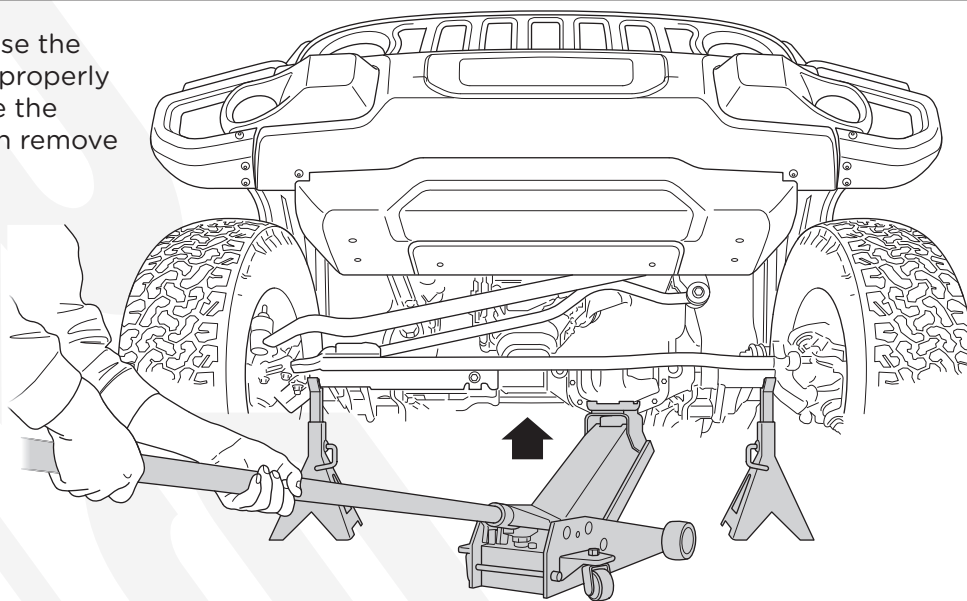

2. Use a hydraulic jack to raise the axle and remove any tension on the front suspension. Use a 21mm socket or wrench to remove the factory track bar bolt on the axle side and frame side. Note the orientation of the factory track bar bolt and flag nut as it will be reused for installation of the RSO Forged Track Bar.

3. Place the new RSO Forged track bar on top of the factory track bar and adjust the length of the RSO track bar until you line up the holes in the bushings. This will help get an approximate length needed prior to installation and make final adjustments easier.

- 4a. Mount the frame side bushing into the frame mounting bracket and secure using the factory bolt, do not overtighten the hardware until all adjustments have been finalized.

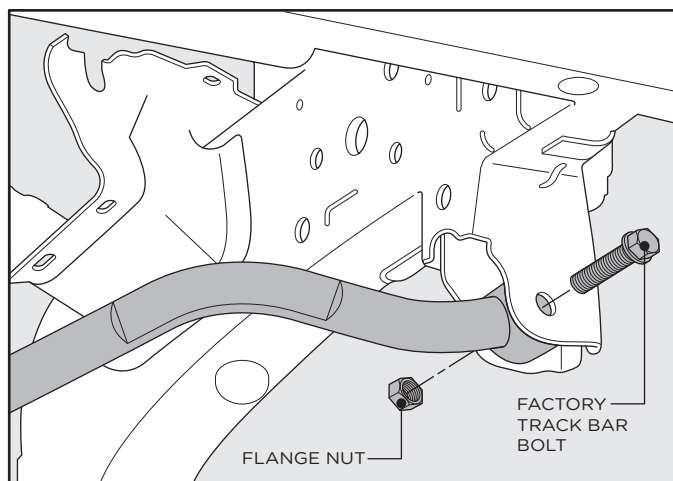

- 4b. Mount the axle side bushing into the axle side track bar mounting bracket and secure using the factory track bar bolt and flag nut, do not over-tighten the hardware until final adjustments have been made.

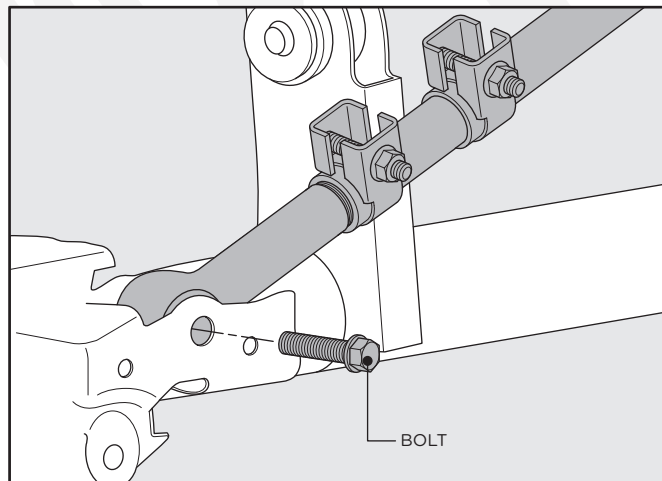

## FORGED ADJUSTABLE FRONT TRACK BAR

SKU# 170118-441500

**RSO**  
SUSPENSION

- 5a.** Reinstall the wheels and lower the vehicle onto the ground and under its own weight. Determine if the axle housing is centered with the chassis by measuring the distance between the tires and chassis, using the same points on each side of the vehicle to ensure accuracy. If the two measurements are the same, the axle is centered. If the two measurements are different, divide the difference in half to determine the amount of required adjustment. The track bar can be adjusted while installed using the adjustment collar (5b). Loosen the collar clamps using an 18mm socket or wrench and turn the collar to lengthen or shorten the track bar. The axle can be shifted using the following methods.

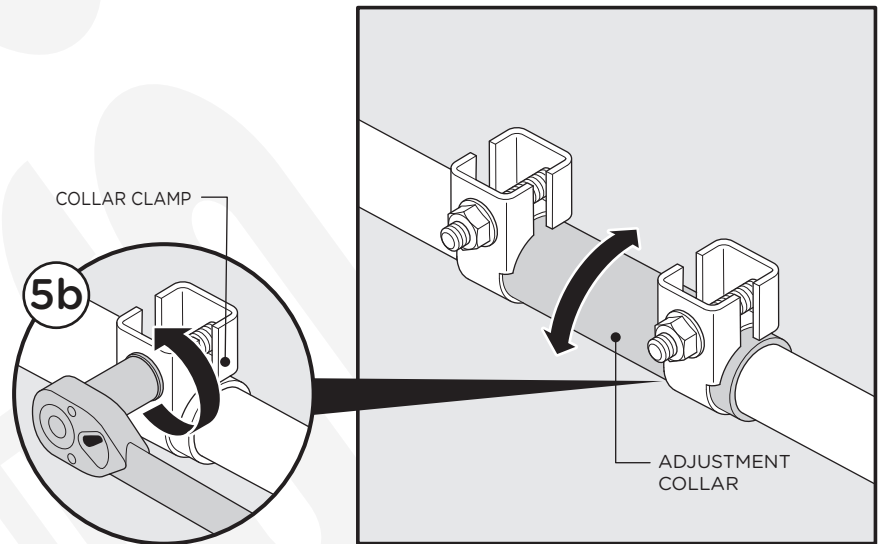

- 6a.** To center the axle under the vehicle you can use the ratchet strap method. Attach a heavy duty ratchet strap to the chassis on one side of the vehicle and to the axle housing on the other side. Tighten the strap in small increments to pull the chassis in alignment with the axle. Take measurements after each adjustment until centered.

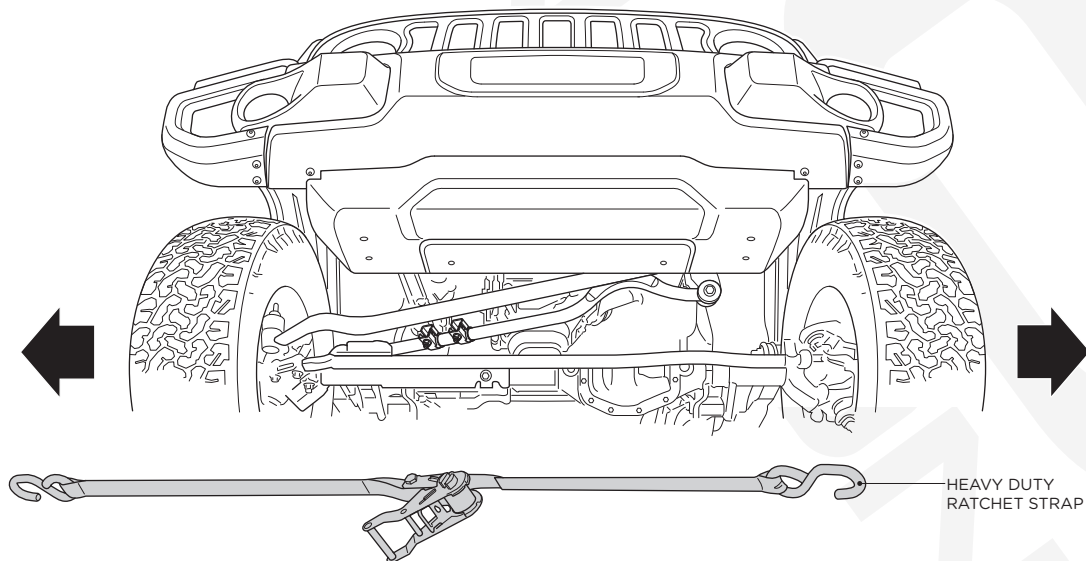

## FORGED ADJUSTABLE FRONT TRACK BAR

SKU# 170118-441500

**RSO**  
SUSPENSION

- 6b.** To center the axle under the vehicle you can also use the Steering Wheel Method. Have a partner turn the steering wheel in small increments to shift the vehicle chassis side-to-side. After each adjustment, have your partner hold the steering wheel steady while you take measurements.
- 7.** Once you have determined the axle is centered torque the factory track bar bolts on the axle and frame side to 90ft/lbs. Secure the adjustment collar using an 18mm socket or wrench and torque the collar bolts to 60ft/lbs.
- 8.** We now recommend a professional alignment. Check all hardware after 100 miles of driving and retorque as necessary.

## REGULAR MAINTENANCE SCHEDULE

Track Bars are essentially maintenance free, however the bushings are a consumable component. See Signs of Wear below for more information.

For the bushings, a visual inspection at every oil change is recommended to detect any accumulation of dirt or debris.

## CLEANING & LUBRICATION

Should dirt accumulate on the bushings, wipe clean with a rag.

## SIGNS OF WEAR

Excessive back and forth play or rattling in the bushings indicates wear. In such instances, it is imperative to replace the affected parts promptly. You can order replacement parts at [www.cyc-engineering.com](http://www.cyc-engineering.com)

Replacement Part numbers for this particular SKU are listed below for your reference.

SKU: REP-BUSHING-2-KIT (Replacement Rubber Bushings)

## TECHNICAL NOTES