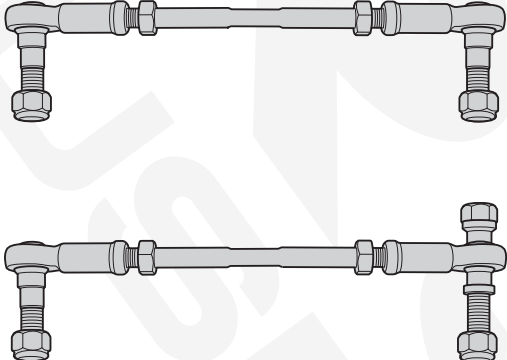
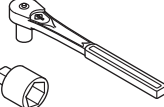
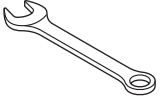
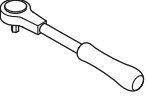
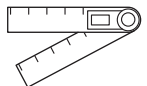

COMPONENTS		TOOLS REQUIRED	
<p>QTY: 2 SWAY BAR END LINKS</p>  <p>DRIVER SIDE</p> <p>PASSENGER SIDE</p>	 <p>METRIC/STANDARD SOCKET WRENCH SET</p>  <p>OPEN- END WRENCHES</p>	 <p>TORQUE WRENCH</p>  <p>ANGLE MEASURING TOOL</p>	

**INSTALLATION NOTES**

Remove all contents from the package and inspect for any damage. Also, verify that all components listed above are included before you begin installation. If anything is missing or damaged please contact us at [customerservice@raptorseries.com](mailto:customerservice@raptorseries.com)

Read through entire installation manual and installation drawings to ensure that you understand all of the components before proceeding with installation.

Prior to installing, you'll want to adjust your Sway Bar End Links to get closer to the ideal sway bar angle. The vehicle will need to be raised to where the axle assembly is in the middle of its travel. Once there, rotate the Sway Bar Arms to where they are parallel with the ground.

Turn the Sway Bar Rod Ends to adjust the length of the End Links to match the distance between the mounting points on the Sway Bar Arms and the axle mount. If the End Link Rods are too long for your specific application, you may cut them to desired length. Cut an equal measurement from each end of the Sway Bar side end link Mount. Make sure not to cut them too short to ensure you can sufficiently thread on the Rod Ends.

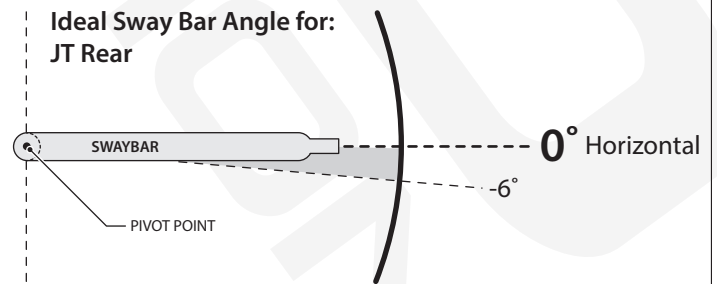
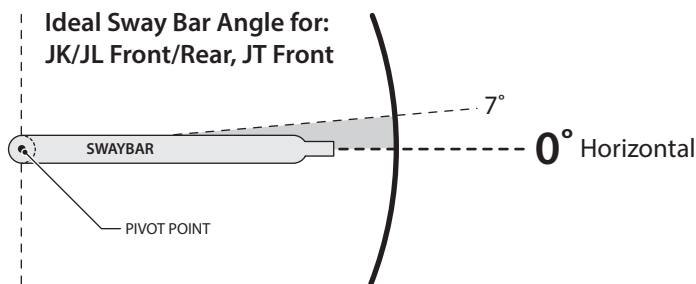

**1.** On the Driver Side fasten one end of the sway bar end link to the sway bar using one 19mm nylock nut. To keep the rod end from spinning, use 17mm open end wrench and tighten 19mm nylock nut. Then repeat the process for the other end to attach to the end link to the axle side mount.

**Driver Side Top**

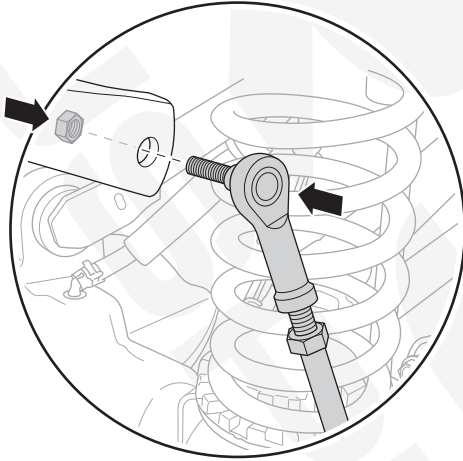

**Driver Side Bottom**

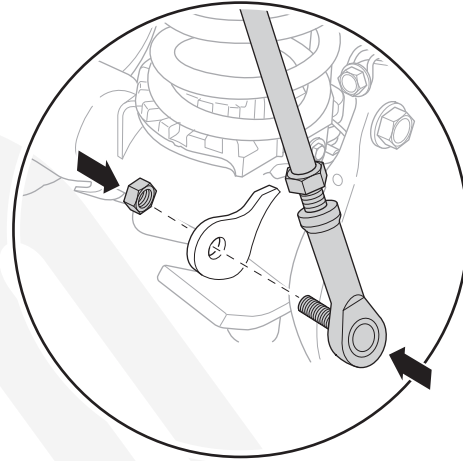

**2.** On the Passenger Side fasten the studded rod end of the sway bar end link to the sway bar using one 19mm nylock nut. To keep the rod end from spinning, use 17mm open end wrench and tighten 19mm nylock. Then on the other end, place the misalignment spacers on each side of the end link as shown, position into axle side mounting location, and fasten with the supplied bolt and 19mm nylock nut.

**Passenger Side Top**

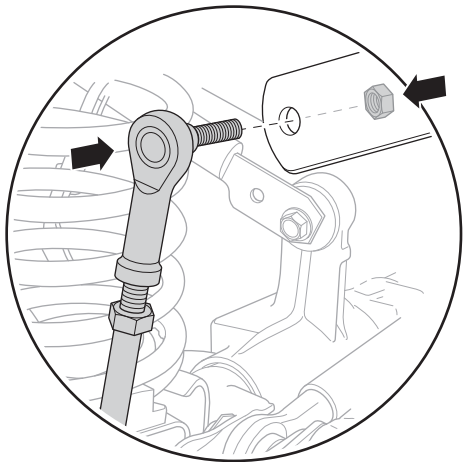

**Driver Side Bottom**

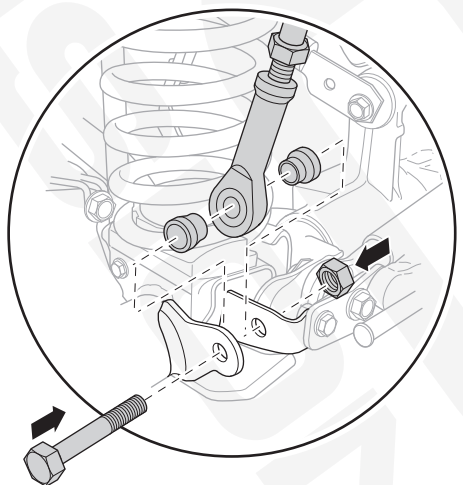

**3.** Once the sway bar end links are connected, adjust accordingly to reach the ideal sway bar angle shown on page 1. Vehicle must be a normal ride height and located on level ground to accomplish this.

## **POST INSTALLATION**

Upon completion of installation and within 50 miles of driving the vehicle, it is necessary to check and ensure all hardware is properly torqued to factory specifications as noted in the factory service manual or as specified in these instructions.

## **IMPORTANT SAFETY INFORMATION**

Modifying your vehicle to improve off-road performance may result in vehicle handling different than as factory equipped, including increased ride-height and/or chassis articulation; reduced lateral stability and higher risk of roll-over or other accident. Also, owner's choice of larger tire and wheel combinations may require additional braking force or increased stopping distances.

Some vehicles may require extended front brake hoses or other modifications to compensate for additional suspension travel. Brakelines must be secured and retain some slack throughout range of suspension travel. Check after installation of your new end links & use longer DOT approved brakelines if necessary.

Never disconnect sway bar when operating vehicle on public roads.

On-highway safety is enhanced by controlling body roll. Never disconnect swaybar when operating on public roads. When disconnected off-road, swaybar must be secured to prevent interference with other suspension components.