

INSTALLATION NOTES

PROFESSIONAL INSTALLATION IS STRONGLY RECOMMENDED!

If you intend to do this installation yourself, please use extreme caution when working under a vehicle that is supported with jack stands. Serious injury or death can occur.

Read through entire installation manual to ensure that you understand all of the steps before proceeding with installation. If these instructions are not properly followed, severe frame, suspension, and tire damage may occur. Product failure or vehicle damage caused by improper installation will not be covered under warranty!

Remove all contents from the package and inspect for any damage. Also, verify that all components listed are included before you begin installation. If anything is missing or damaged please contact us at customerservice@cyc-engineering.com - IMPORTANT: DO NOT INSTALL DAMAGED PARTS!

COMPONENTS

Qty: 1 HD Adjustable Rear Track Bar

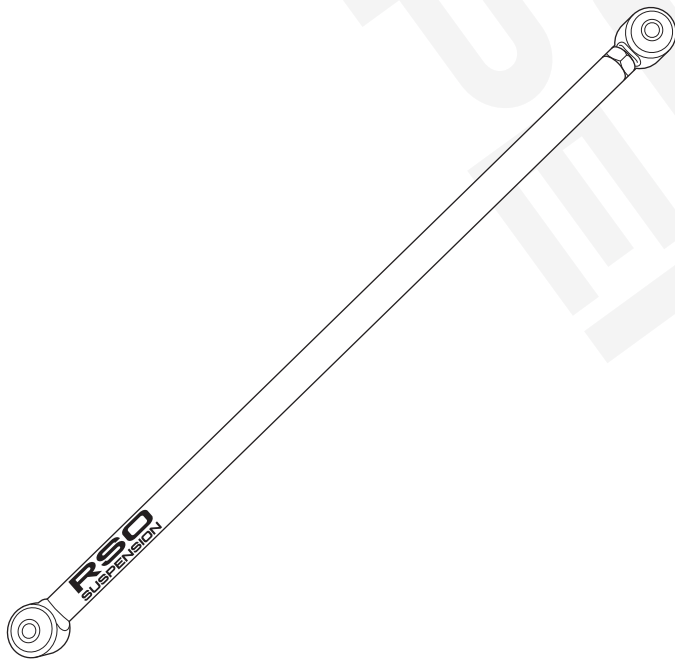

TOOLS REQUIRED



Jack Stands

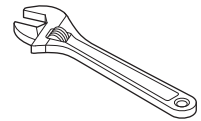

Adjustable Wrench

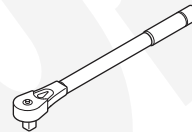

Torque Wrench

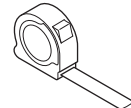

Tape Measure

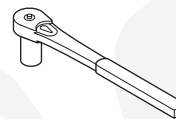

21mm Socket/Wrench

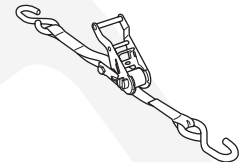

Ratchet Strap



Jack

1. Use properly rated jack stands to support the vehicle, chock the front tires to ensure no movement while working under your vehicle. Once the back of the vehicle is on the ground and secured, remove the rear wheels.
2. Using a properly rated hydraulic jack under the axle housing, raise the jack to remove tension on the rear suspension and remove the factory rear track bar using a 21mm socket or wrench. Keep the factory hardware as it will be reused for installation.

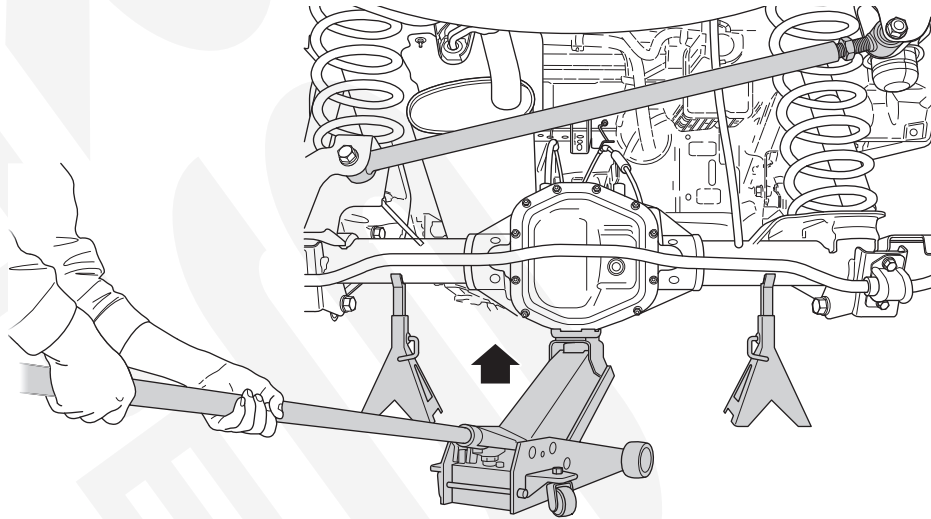

3. Place the new HD Forged track bar on top of the factory track bar and adjust the length of the RSO track bar until you line up the holes in the bushings. This will help get an approximate length needed prior to installation and make final adjustments easier.

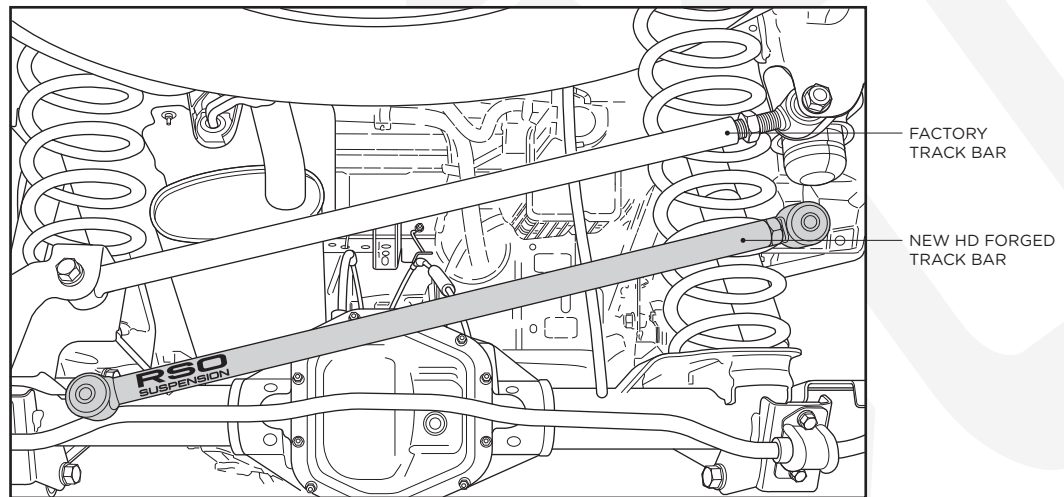

- 4a.** Mount the frame side bushing into the frame mounting bracket and secure using the factory bolt, do not overtighten the hardware until all adjustments have been finalized.

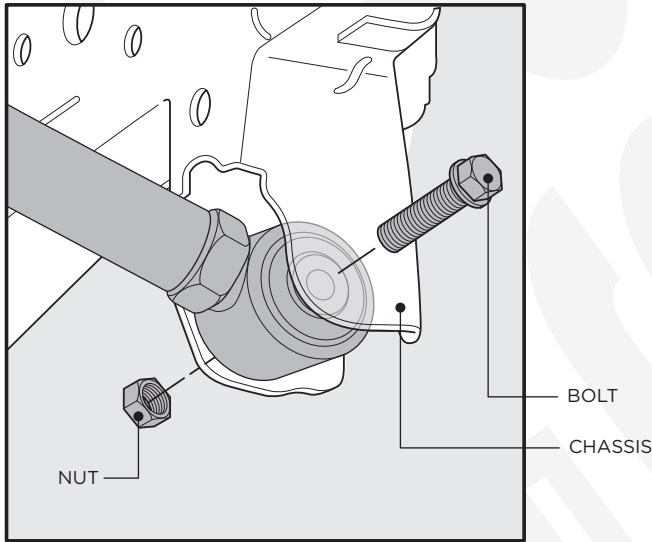

- 4b.** Mount the axle side bushing into the axle side track bar mounting bracket and secure using the factory track bar bolt, do not over-tighten the hardware until final adjustments have been made.

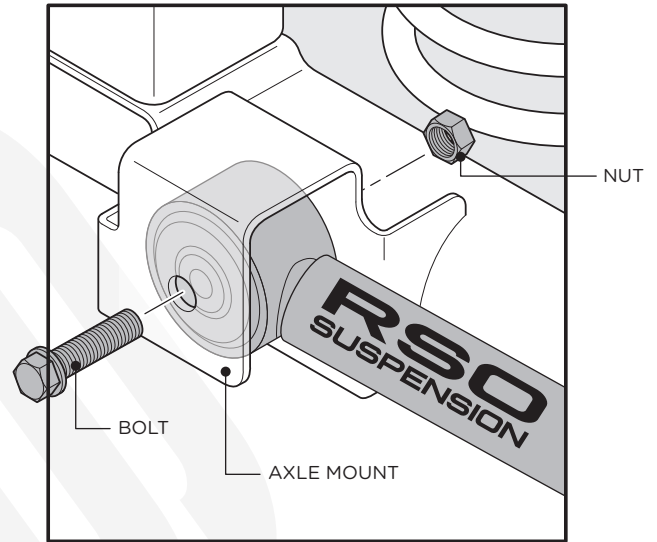

- 5a.** Reinstall the wheels and lower the vehicle onto the ground and under its own weight. Determine if the axle housing is centered with the chassis by measuring the distance between the tires and chassis, using the same points on each side of the vehicle to ensure accuracy. If the two measurements are the same, the axle is centered. If the two measurements are different, divide the difference in half to determine the amount of required adjustment.

- 5b.** The track bar can be adjusted by loosening the jam nut and rotating the adjustable forged end. To do this remove the axle side bolt using a 21mm socket or wrench, adjust the end by rotating then reinstall on the axle side track bar mount. You may need to repeat this step multiple times until the axle is centered under the vehicle.

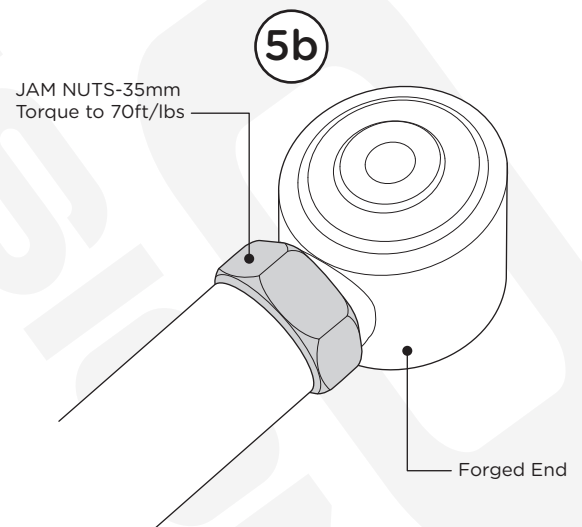

6a. To center the axle under the vehicle you can use the ratchet strap method. Attach a heavy duty ratchet strap to the chassis on one side of the vehicle and to the axle housing on the other side. Tighten the strap in small increments to pull the chassis in alignment with the axle. Take measurements after each adjustment until centered.

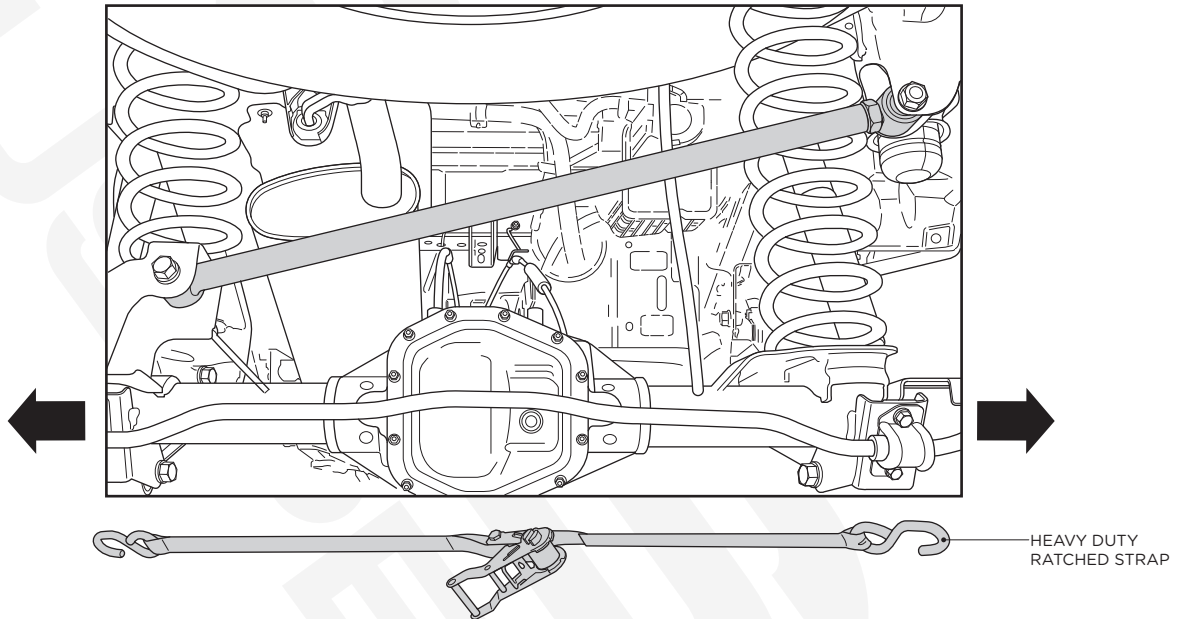

- 7.** Once you have determined the axle is centered, tighten the jam nut and adjustment collar using a large adjustable wrench and torque to 70ft/lbs.
- 8.** We now recommend a professional alignment. Check all hardware after 100 miles of driving and retorque as necessary.

REGULAR MAINTENANCE SCHEDULE

Track Bars are essentially maintenance free, however the bushings are a consumable component. See Signs of Wear below for more information.

For the bushings, a visual inspection at every oil change is recommended to detect any accumulation of dirt or debris.

CLEANING & LUBRICATION

Should dirt accumulate on the bushings, wipe clean with a rag.

SIGNS OF WEAR

Excessive back and forth play or rattling in the bushings indicates wear. In such instances, it is imperative to replace the affected parts promptly. You can order replacement parts at www.cyc-engineering.com

Replacement Part numbers for this particular SKU are listed below for your reference.

SKU: REP-BUSHING-2-KIT (Replacement Rubber Bushings)

TECHNICAL NOTES