

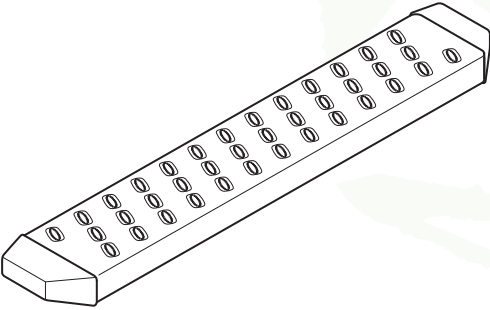





HITCH STEP INSTALLATION

SKU# 2100-HITCH-STEP

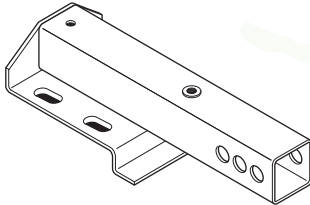
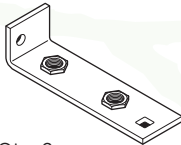
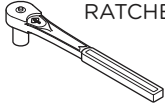

COMPONENTS		HARDWARE	
			Qty: 4 M8 x 40MM Hex Head Bolts
			Qty: 4 M8 Flat Washers
			Qty: 4 M8 Lock Washers
Qty: 1 Hitch Step			
			
Qty: 1 Hitch Mount Bracket			
			
	Qty: 2 Bolt Adapter Plates		
TOOLS REQUIRED		INSTALLATION NOTES	
	RATCHET		13MM SOCKET
			TORQUE NOTE: Bolts and nuts should be torqued to 15-20 ft lbs.
<p>Remove all contents from the package and check brackets for any damage. Also, verify that all components and hardware listed above are included before you begin installation.</p> <p>If anything is missing or damaged, please contact us at customerservice@cyc-engineering.com</p> <p>Read through the entire installation manual and installation drawings to ensure that you understand all the components and hardware before proceeding with installation. NOTE: When installing the brackets, all hardware must be left loose until all the items are attached.</p>			

HITCH STEP INSTALLATION

SKU# 2100-HITCH-STEP

Raptor
Series

1. Place the Hitch Step face down (1a). Place each Bolt Adapter Plate onto the underside of the Hitch Step and through the notch (1b). Slide Plates into channels of Hitch Step and position plates so they line up with the two small holes on the lip of the Hitch Step towards the center (1c).

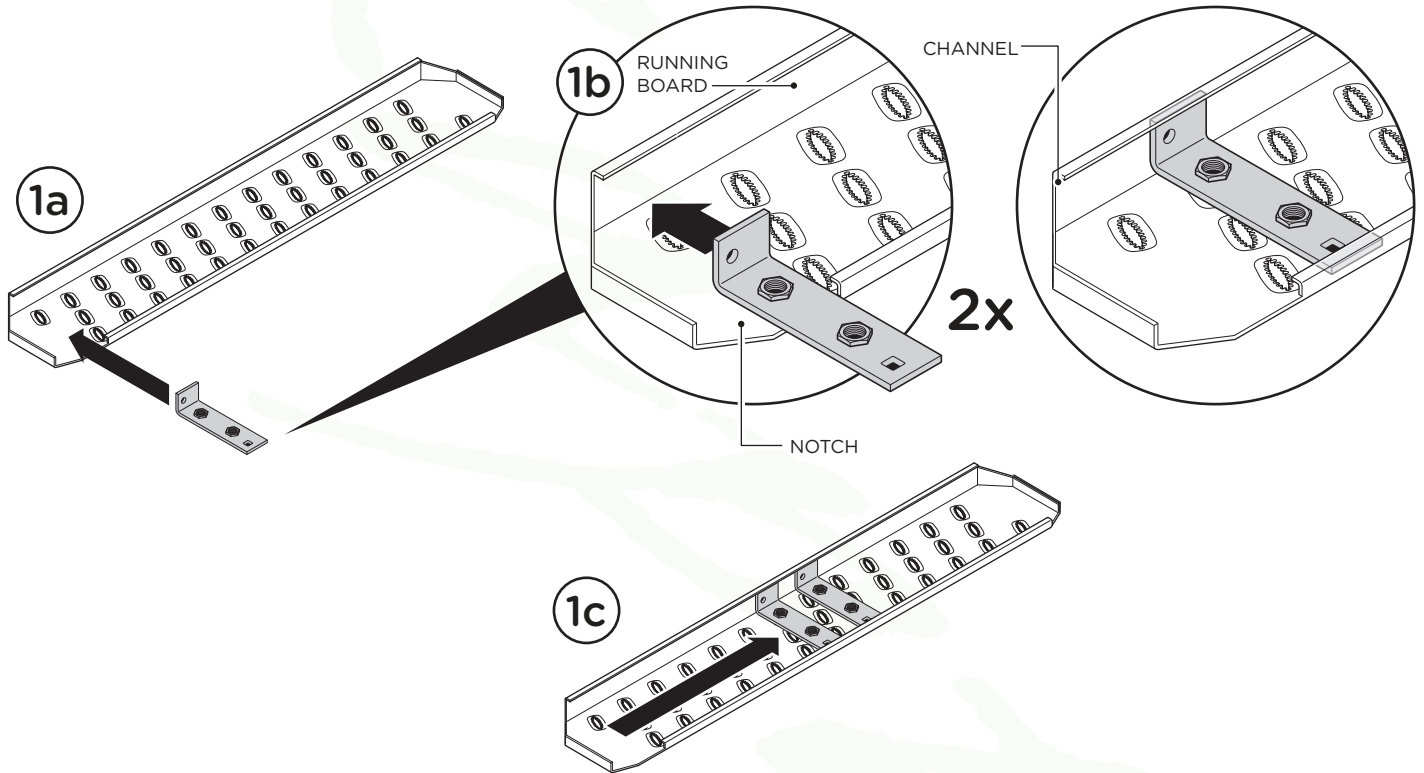

2. Slide the bottom of the Hitch Mount Bracket between the Hitch Step lip and the bolt Adapter Plate, the front curved edge of the Hitch Mount Bracket will rest on top of the channel of the Hitch Step to show the logo.

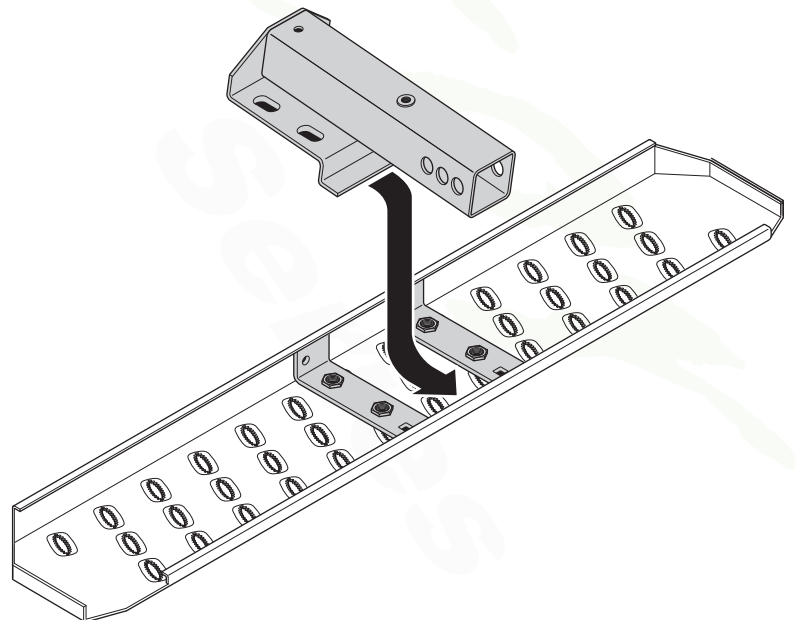

HITCH STEP INSTALLATION

SKU# 2100-HITCH-STEP

Raptor
Series

3. Make sure the Hitch Mount Bracket is centered on the Hitch Step. Fasten the Hitch Mount Bracket to the Bolt Adapter Plates by using (4) M8 Hex Head Bolts, (4) M8 Lock Washers and (4) M8 Flat Washers. Tighten the hardware until the Split Lock Washer is flat between the M8 Flat Washer and M8 Hex Head Bolt.

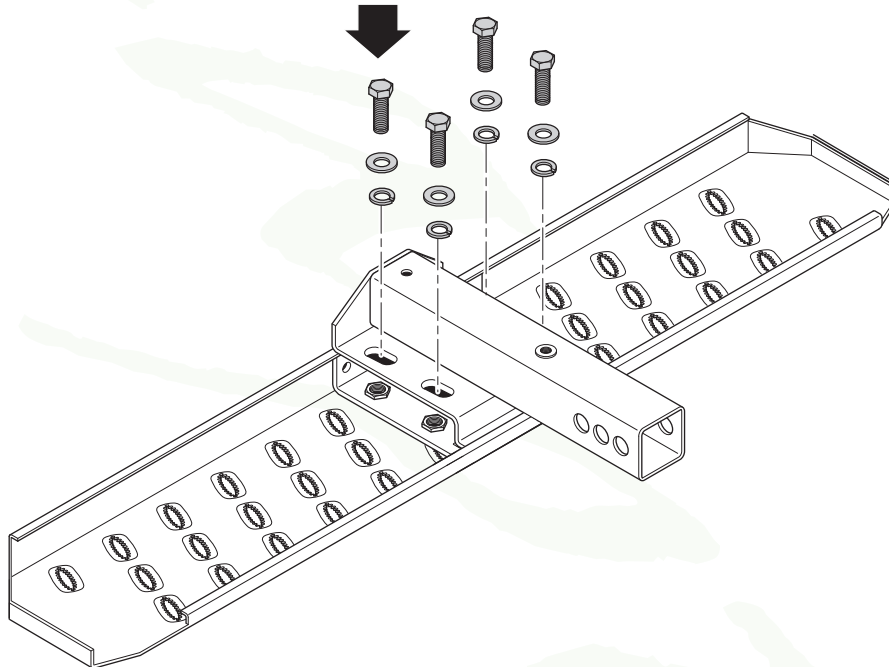

4. Mount the Hitch step into your 2-inch hitch receiver and secure it with a Hitch Pin.