

2018 JEEP WRANGLER JL FRONT BUMPER WITH WINCH

MAGNUM

Bumper Components:

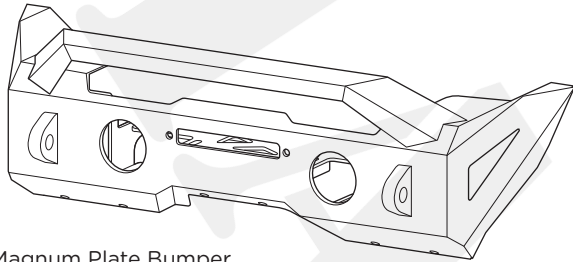

Magnum Plate Bumper
Qty 1

Bumper Hardware:



M10 1.50 Hex
Head Nuts
Qty 8

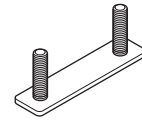

M10 T-Bolts
Qty 4



M10 Flat
Washers
Qty 8

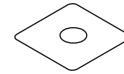

M10 Plastic
Push Nuts
Qty 8



M10 Lock
Washers
Qty 8

Skid Plate Components:

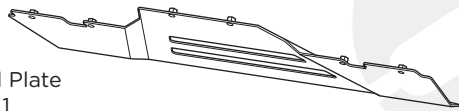

Skid Plate
Qty 1

Skid Plate Hardware:



3/8"-16 x 1" SS
Button Head Bolts
Qty 8



Skid Plate
Mounting Tabs
Qty 2



10-3/8" SS
Flat Washers
Qty 10



M8 T-Bolts
Qty 2

OE Fog Light Adapter Bracket Components:

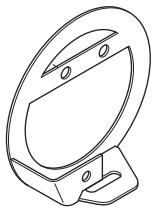

OE Fog Light
Adapter Bracket
Qty 2

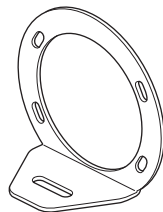

OE Fog Light
Adapter Bracket 2
Qty 2

OE Fog Light Adapter Bracket Hardware:



M6-1.00 x 20mm
Hex Head Bolts
Qty 8



M8-1.25
Hex Head Nuts
Qty 6



M6-1.00 Hex
Head Nuts
Qty 8



M8 Flat
Washers
Qty 8



M6 Lock
Washers
Qty 8



M8 Lock
Washers
Qty 6



M8 1.25 x 30mm
Hex Head Bolts
Qty 2

Tools Required:

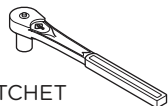

RATCHET



M10
SOCKET



M8
SOCKET



M6
SOCKET

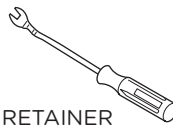

RETAINER
REMOVAL TOOL

Installation

1. Start by unplugging Factory Wiring Harness on Front Bumper (located on outside face of passenger side frame rail).
2. Remove two (2) Plastic Push Pins from Plastic Filler Panel on top of Frame Rails by using a pry tool.
3. Remove two (2) Bolts attaching Skid Plate to the Frame. Now remove six (6) Plastic Push Pins attaching Skid Plate to the Front Bumper Assembly.
4. Remove eight (8) Bolts attaching Bumper Assembly to the Frame. There are four (4) per side. Carefully remove Bumper from vehicle and set to the side.
5. Remove twelve (12) Plastic Push Pins from the Front Bumper Assembly to access to OEM Fog Lights: there are six (6) per side.

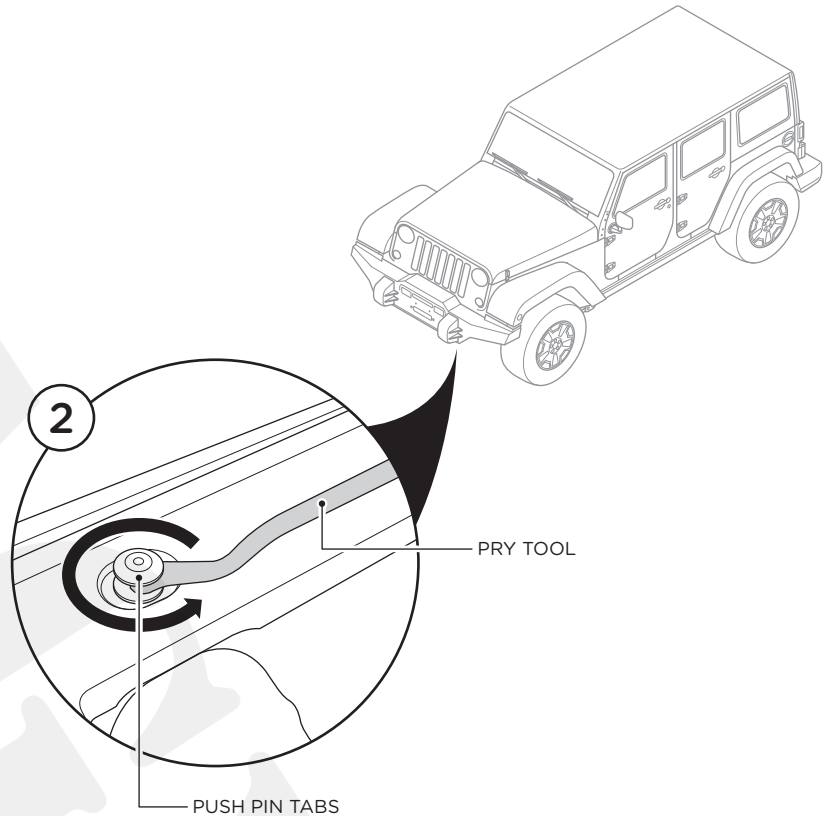

6. Now, you will need to remove the OEM Fog Lights to install into the Magnum Bumper. Start by removing eight (8) Bolts retaining the Lights to the Factory Bumper. There are four (4) per Light. Once unbolted, remove from Harness and set aside.

7. Now that the Lights are removed, you will need to remove the Wiring Harness from the Factory Bumper Assembly. To do this, you will need to remove the internal components from the outside shell of the Bumper and unclip the Harness from the Bumper.

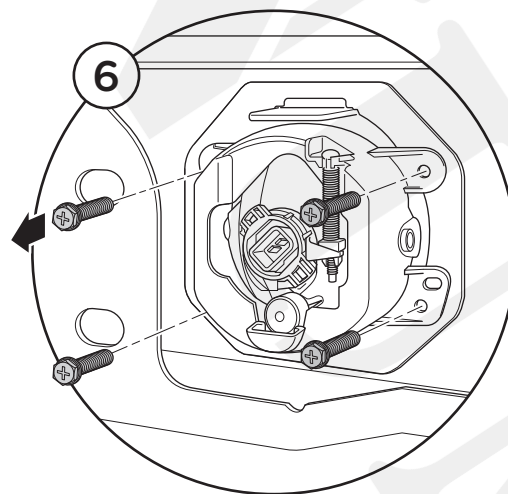

8. Take OEM Fog Lights and attach them to the Magnum bumper using provided M6 Hardware.

If you have the Molded Plastic OEM Front Bumper for Sahara and Rubicon models, you will use Fog Light Adapter Brackets with the provided M6 hardware (you will need to drill the holes on light housing to fit the M6 bolts (8a).

If you have the Sport Model JL with Molded Plastic OEM Front Bumper, you will use the Fog Light Adapter Bracket shown in (8b).

9. If you have the Steel OEM Front Bumper you will attach the Fog Lights directly to the Bumper using the provided M6 hardware (9a).

Once for lights are attached to the Bracket, you will attach Bracket to tab on Bumper using provided two (2) M8 bolts, hex nuts, lock washers and four (4) flat washers (9b).

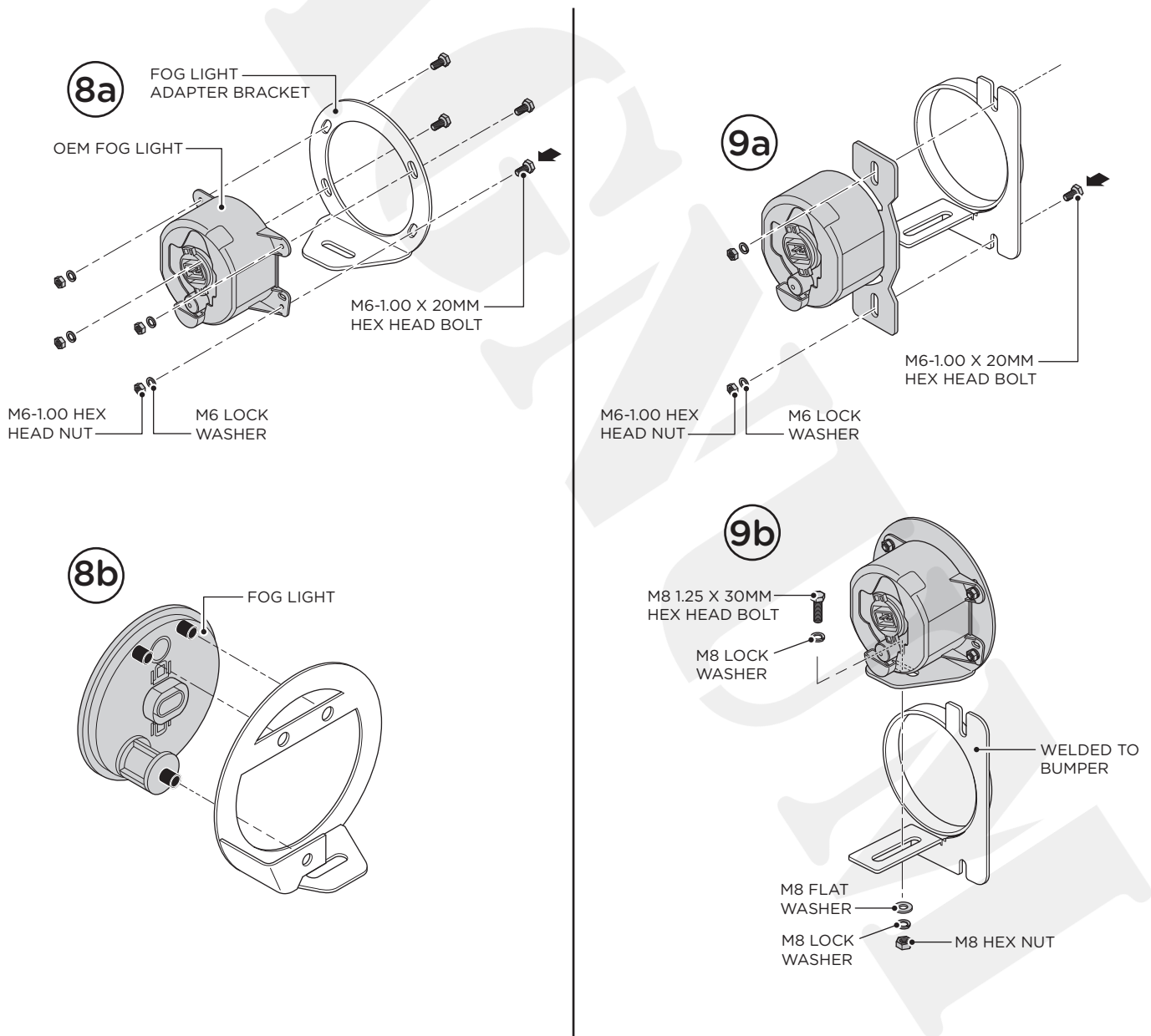

10. With help, lift and align Bumper to the Frame.

11. Attach provided T-bolts to Magnum bumper using four (4) M10 Plastic Push Nuts.

With help, lift and align Bumper to the Frame and attach using provided four (4) M10 Flat Washers, four (4) Lock Washers, four (4) Hex Nuts per side.

Adjust Bumper and snugly fasten hardware to the Frame.

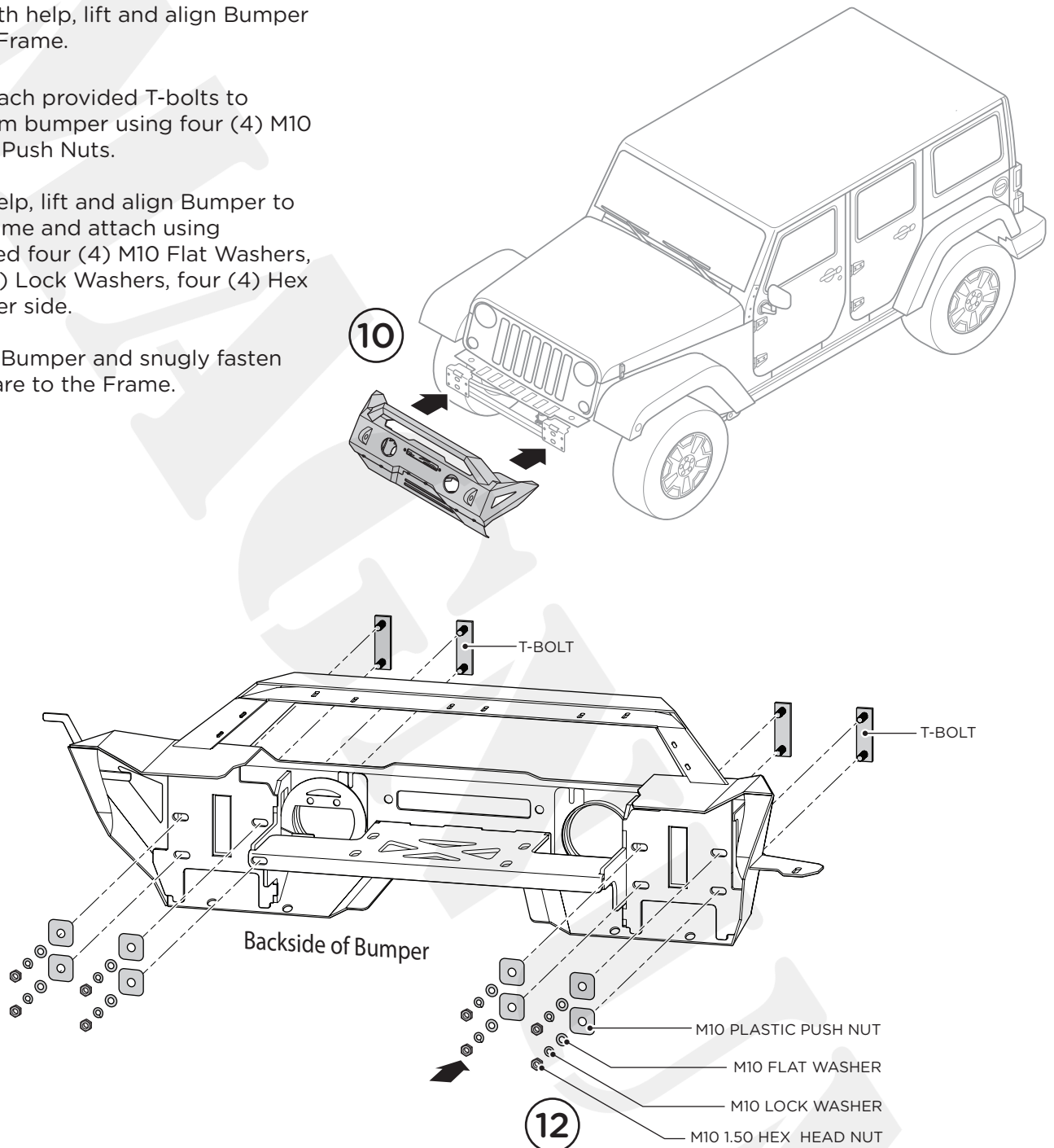

12. Reattach Factory Wiring Harness to the OEM Fog Lights and secure the Harness to the Bumper as needed. Once secured, attach Harness to plug on passenger side of frame.

13. Attaching Winch options prior to installation of Skid Plate to allow for easier access to mounting locations to securely fasten Winch to Bumper. Install using manufacturer's guidelines.

14. Once all winch options are installed, attach Skid Plate to Bumper using six (6) 3/8" Stainless Button Head Bolts and six (6) Flat Washers. Loosely fasten.

15. Once Skid Plate has been aligned, attach the Skid Plate Mounting Tabs to the frame using provided two (2) M8 T-bolts and four (4) M8 Flat Washers, four (4) Lock Washers and four (4) Hex Nuts.

16. Attach Skid Plate Mounting Tabs to Skid Plate using remaining 3/8" Stainless Hardware. Tightly fasten all hardware to Skid Plate and Skid Plate Mounting Tabs.

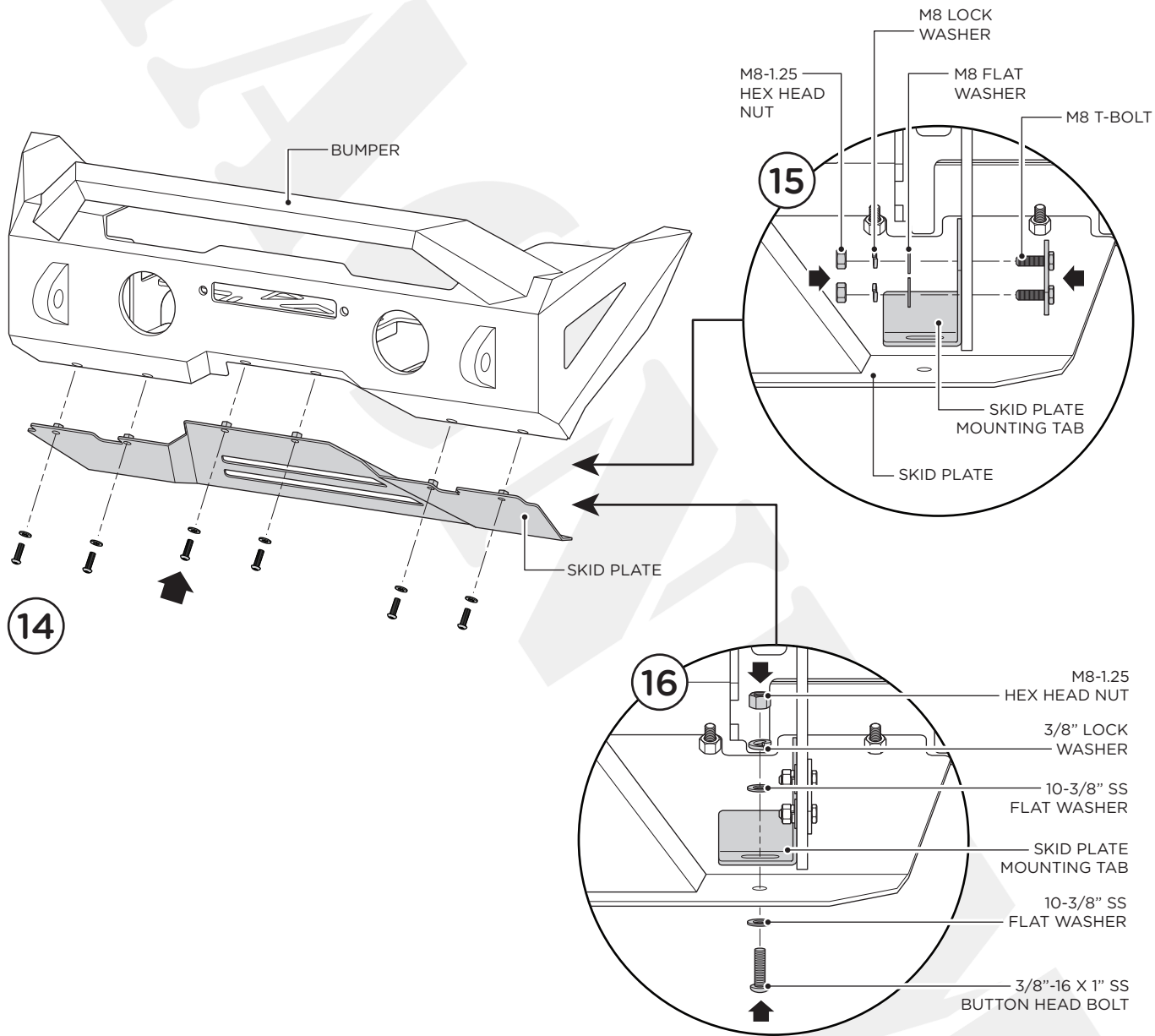

17. Take OEM Fog Light assembly from Factory Bumper.

18. Remove OEM Fog Light from factory housing by compressing Flanges on Pins holding them together.

19. The Fog Light should retain the Black Pins to reinstall into Fog Light Adapter Bracket.

20. The Fog Light should snap into the Fog Light Adapter Bracket using the Black Retainer Pins. If Light Assembly is loose, you may add 3/8" Flat Washers between Retainer Pins and Fog Light Adapter Bracket to reduce movement.

21. Use supplied M8 hardware to install Light Assembly to Light Mounting Tab. Adjust assembly so the Fog Light Lens is the only thing protruding from the front face of the Bumper and tighten M8 hardware.

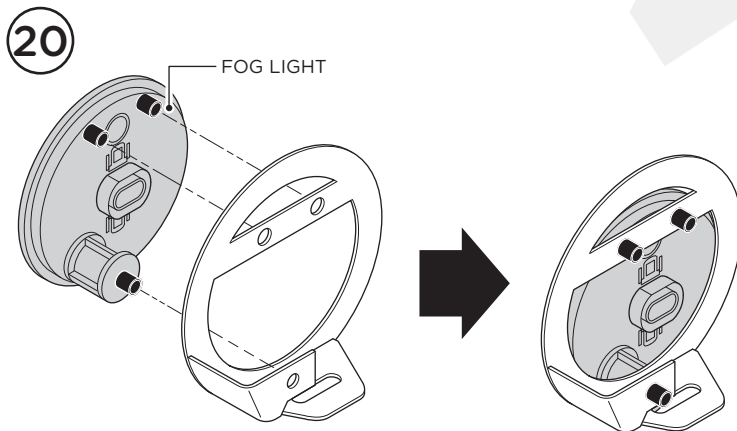
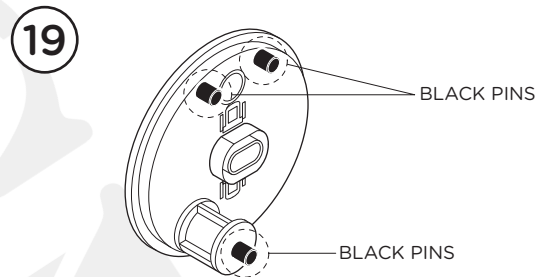
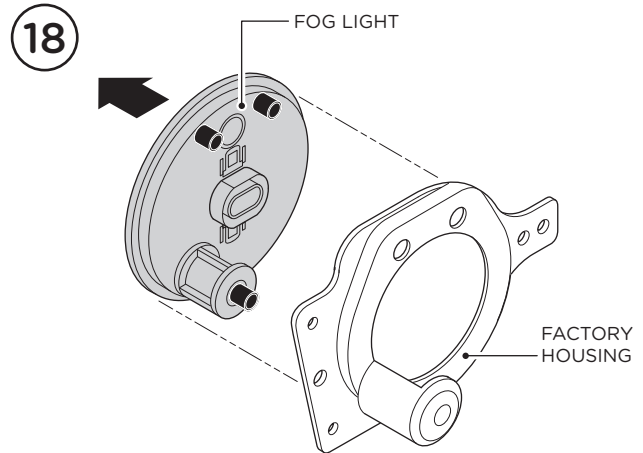

M6-1.00 HEX HEAD NUT — M6 LOCK WASHER

