

MAGNUM FRONT WINCH RT STYLE BUMPER

SKU# FBM83TYN-RT

MAGNUM

Bumper Components:

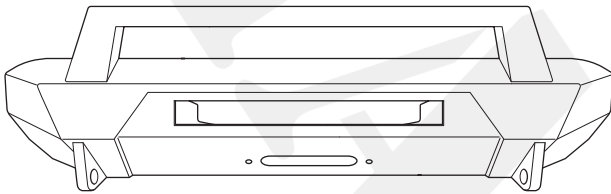

RT Front Bumper
Qty 1

Bumper Hardware:

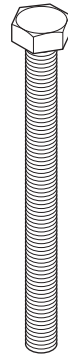

12MM X 120mm
Long Hex Bolt
Qty 2



12MM Nylon
Lock Nut
Qty 2



12MM Flat
Washer
Qty 4

Bolt Plate:

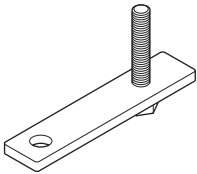

8MM Bolt Plate
Qty 2

Bolt Plate Hardware:



8MM Hex
Head Nut
Qty 2



8MM Flat
Washer
Qty 2

Light Bracket Kit:

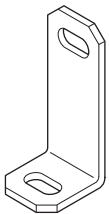

"L" Light Bracket
Qty 2

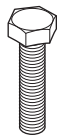

8MM X 25MM
Hex Head Bolts
Qty 2



8MM
Flat Washers
Qty 4



8MM Nylon
Lock Nuts
Qty 2

Installation Notes:

Remove the contents from the box. Verify that all parts are present. Read instructions carefully before proceeding with the installation.

Assistance is recommended to avoid possible injury or damage to your vehicle.

Some cutting on your factory front bumper is required.

MAGNUM FRONT WINCH RT STYLE BUMPER

Tools Required:

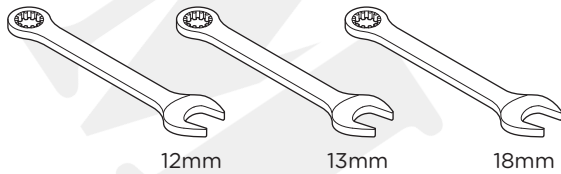

OPEN END WRENCH

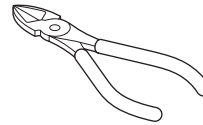

WIRE CUTTERS

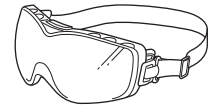

SAFETY GLASSES

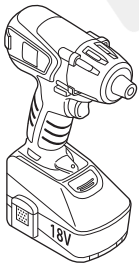

DRILL

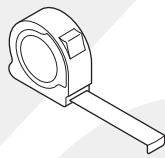

TAPE MEASURE

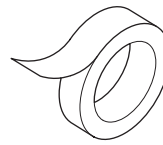

MARKING TAPE

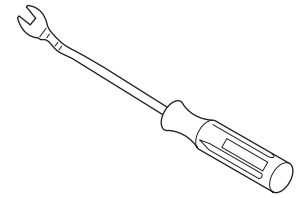

RETAINER
REMOVAL TOOL

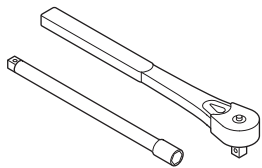

SOCKET WRENCH
w/EXTENSION

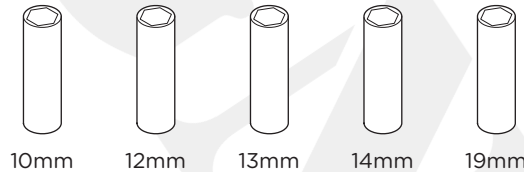

SOCKETS

SOCKET EXTENSION

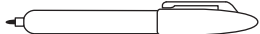

MARKING PEN

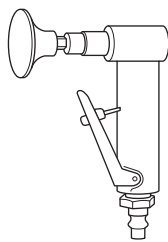

ANGLE GRINDER

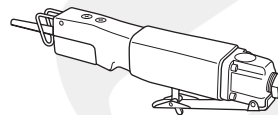

BODY SAW

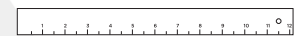

RULER

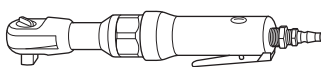

AIR RATCHET

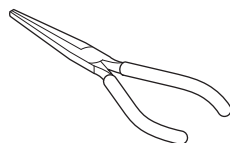

NEEDLE NOSE PLIERS

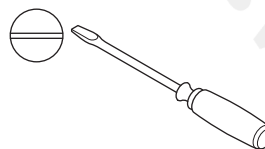

FLAT SCREWDRIVER

MAGNUM FRONT WINCH RT STYLE BUMPER

PROCEDURE:

REMOVE CONTENTS FROM BOX. VERIFY ALL PARTS ARE PRESENT. READ INSTRUCTIONS CAREFULLY BEFORE STARTING INSTALLATION. ASSISTANCE IS RECOMMENDED TO AVOID POSSIBLE INJURY OR DAMAGE TO THE VEHICLE. CUTTING OE FRONT BUMPER IS REQUIRED.

1. Remove the Air Dam (if present) from the bottom of the Bumper using a 10mm socket.

Remove the Skid Plate from the bottom of the Bumper using a 10mm socket.

2. Open the hood and remove the Plastic Cover from the top of the radiator and Plastic Grille.
3. Remove Bolts located on both the underside (3a) and the top (3b) of the Plastic Grille using a 10mm socket. Using a Retainer Removal Tool, remove the Retainer Clips at each end of Plastic Grille (3c)

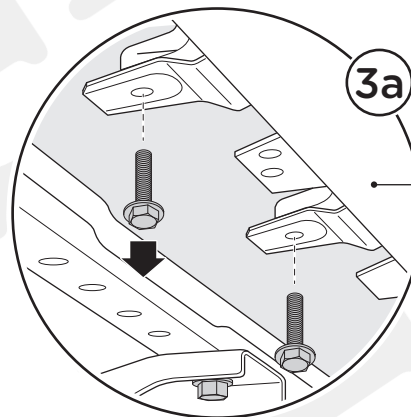
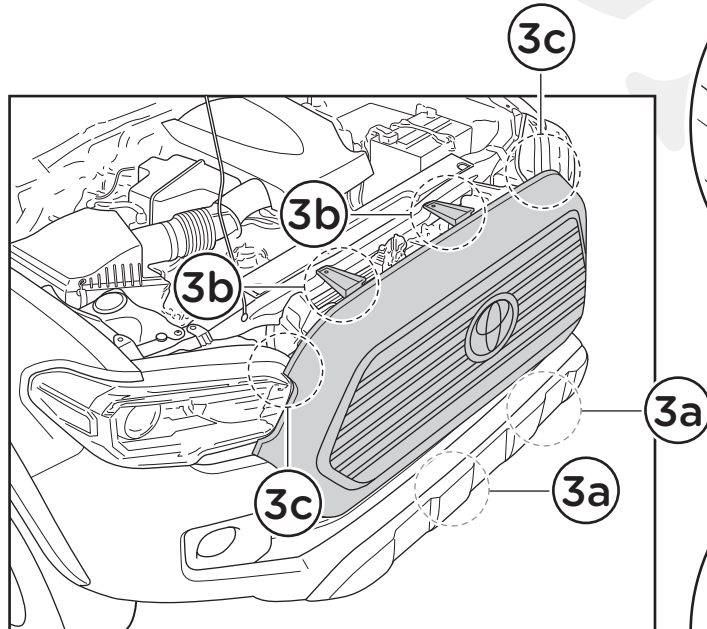
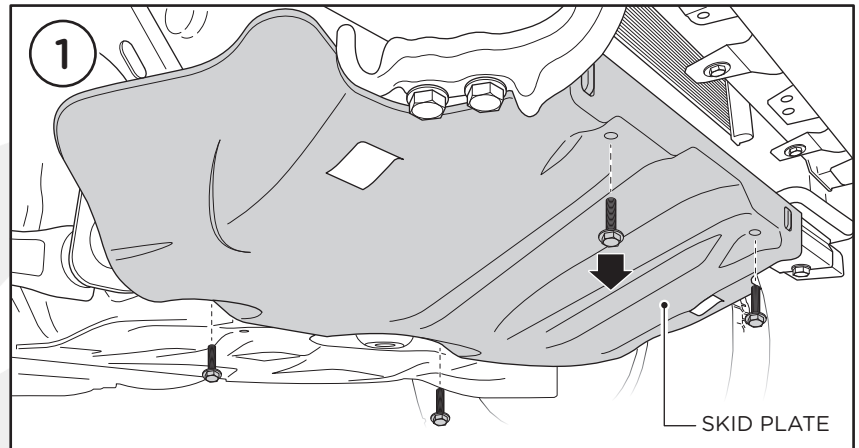

Underside of Plastic Grille

UNDERSIDE OF PLASTIC GRILLE

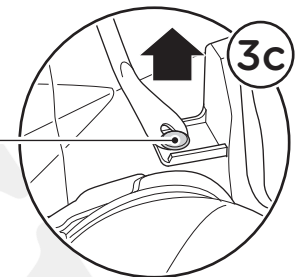

RETAINER CLIP

Side of Grill

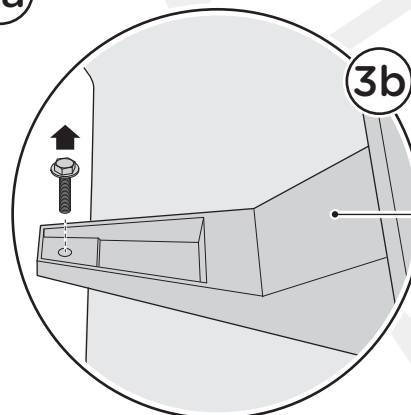

Top of Plastic Grille

PLASTIC ARM LOCATED ON TOP OF PLASTIC GRILLE

MAGNUM FRONT WINCH RT STYLE BUMPER

4. Remove the wiring harness prior to removing the grill by first locating the two (2) plastic clips and pushing downward on each plastic clip (4a). Separate the plug by pressing down and pulling back (4b). Remove the Plastic Grille from vehicle by lifting upward on the Plastic Arms (4c).

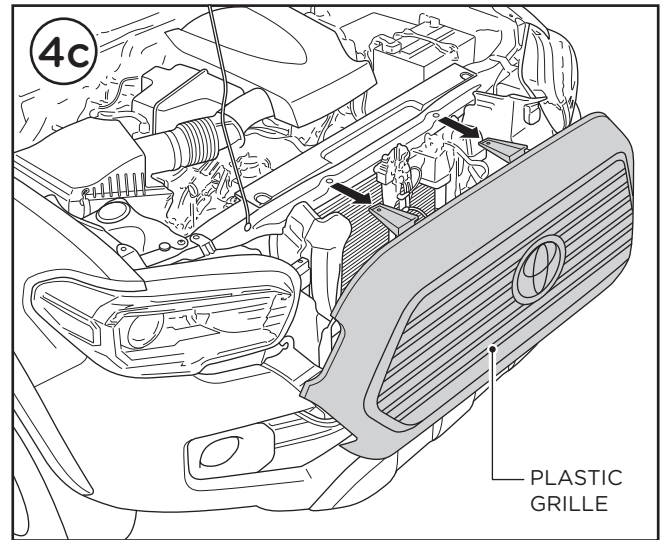
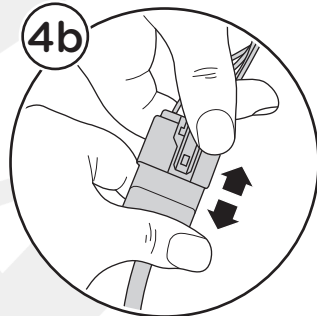
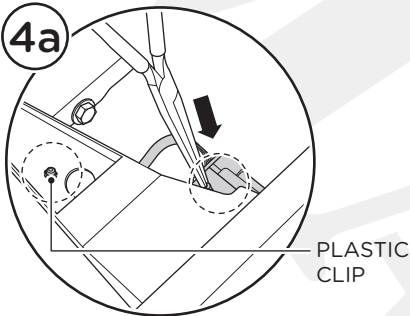

5. Using Removable Tape (masking tape for example), cover the top (5a), driver side (5b) and passenger side (5c) of the Bumper in the approximate areas that will be cut.

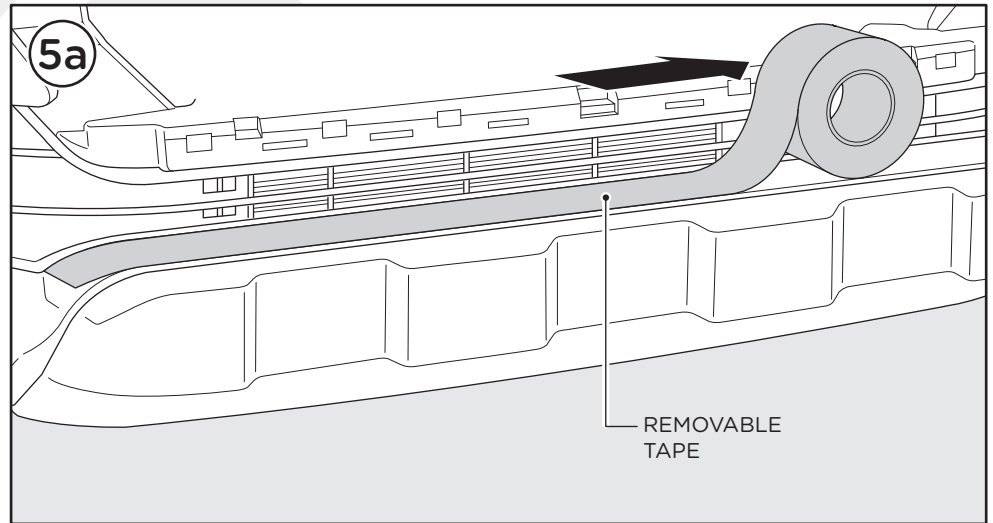

Top of Bumper

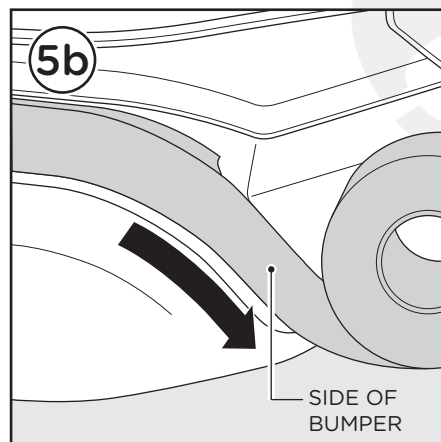

Driver Side Bumper

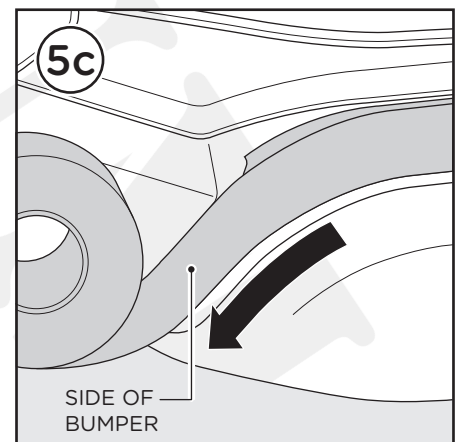

Passenger Side Bumper

MAGNUM FRONT WINCH RT STYLE BUMPER

6. Move to the top of the Bumper and locate the approximate center of the Bumper. Measure and place a mark 19-20mm (3/4") from the License Plate Bracket back toward the Plastic Grille, (6a). If there is no front License Plate, measure from the Bumper pad toward the Plastic Grille. With a long straight edge, draw a straight line across the top of the Bumper, (6b).

NOTE: Use a marking pen and draw onto the tape, not the painted finish.

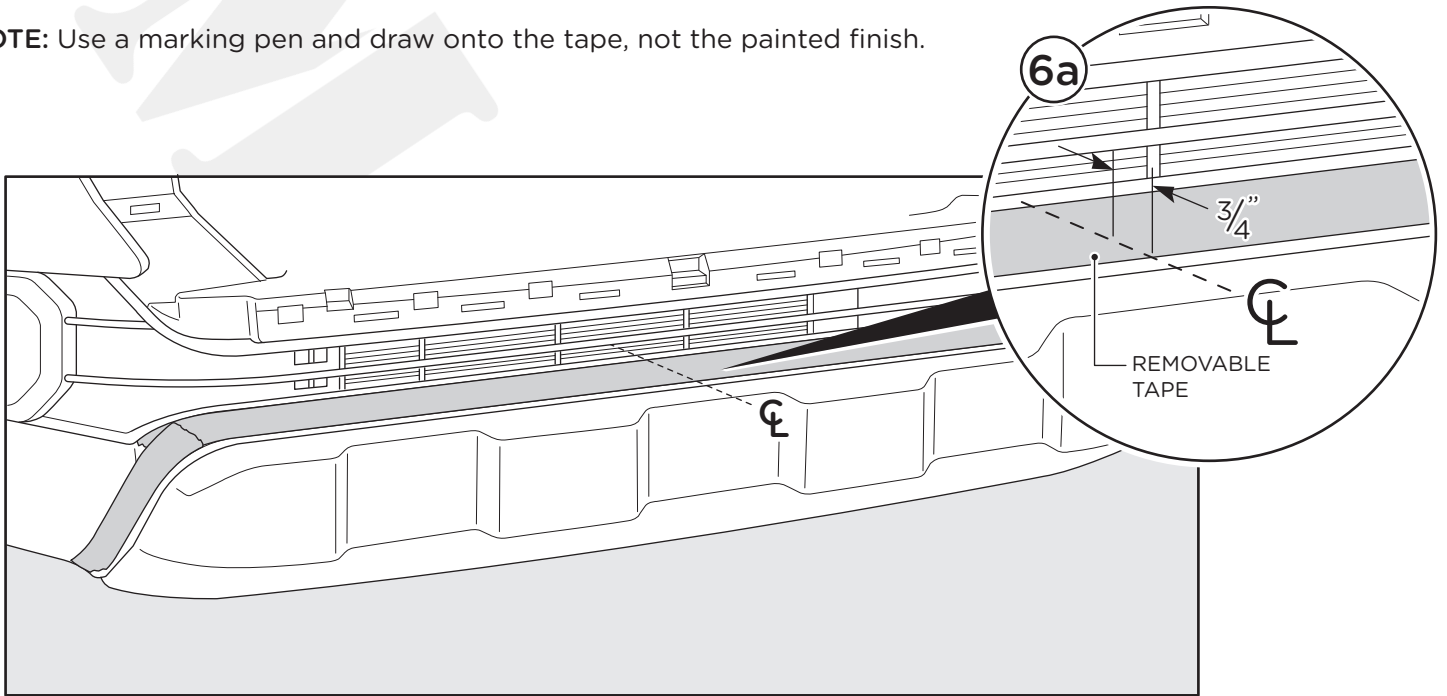

Top of Bumper

NOTE: Line shown as dashed for clarity. You may draw a solid line.

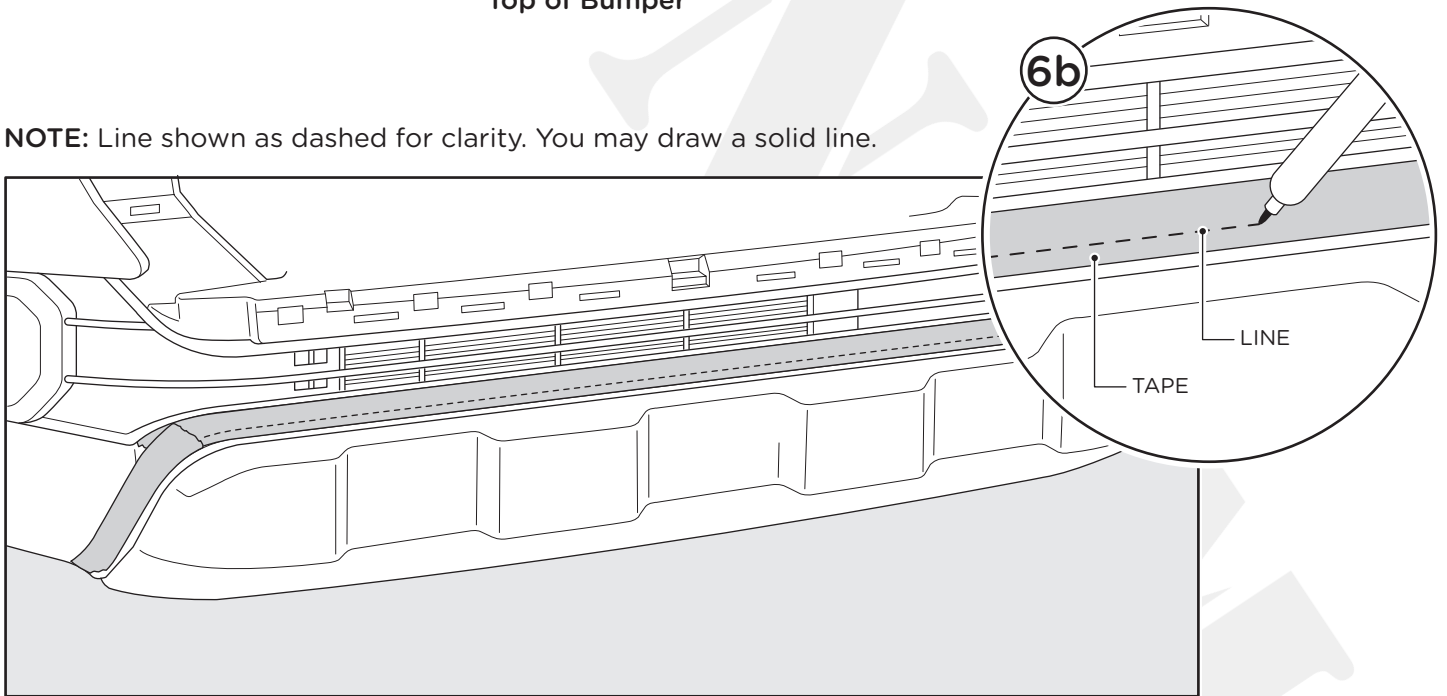

Top of Bumper

MAGNUM FRONT WINCH RT STYLE BUMPER

7. On the driver side of the Bumper, mark along the contour/bend line in the Bumper to the top of the Bumper. Draw a short angled connecting line from the contour line to the long line across the top of the Bumper. Repeat for the passenger side of the Bumper.

NOTE: Line shown as dashed for clarity. You may draw a solid line.

8. To remove Bumper, locate fastening points under the wheel wheel on both sides of the bumper. (8a). First, using a 10mm socket wrench, remove the 10mm Bolt (8b). Next, using a screwdriver and a retainer removal tool, loosen and remove the Retainer Clips to release the end of the Fender Flare (8c). Pull the Fender Flare straight out to release 8d).

NOTE: The Fender Flare does not need to be completely removed, only the front end of the Fender Flare attached to the Bumper needs to be released to remove Bumper.

9. If your model comes equipped with factory fog lights, unplug the harness which leads to the bumper and remove the retainer clip that is holding the harness in place using a retainer removal tool.

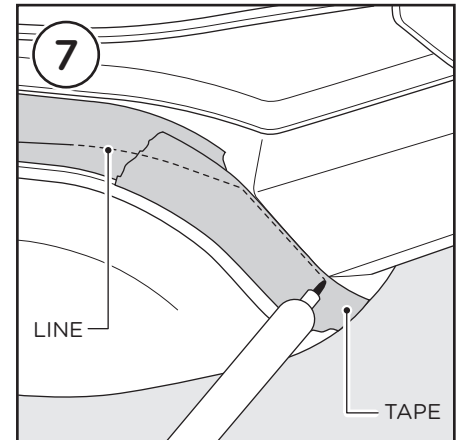

Driver Side Bumper

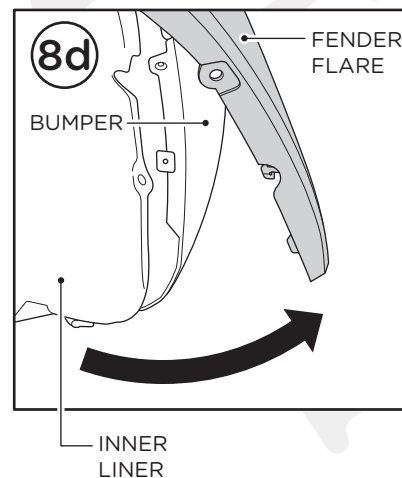
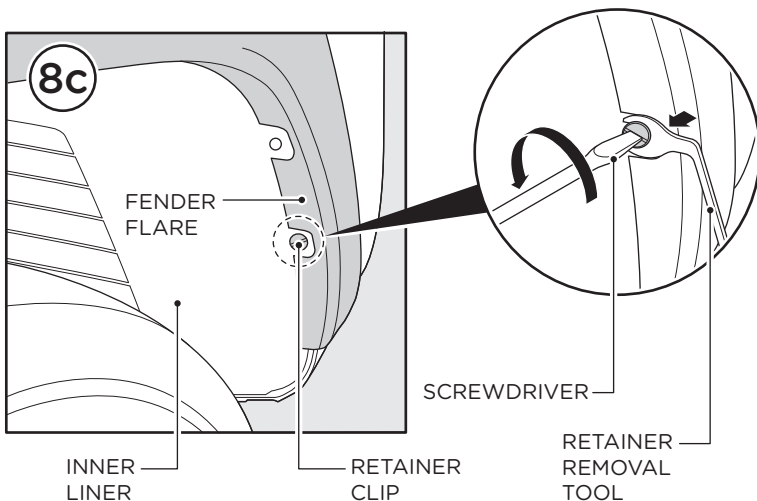
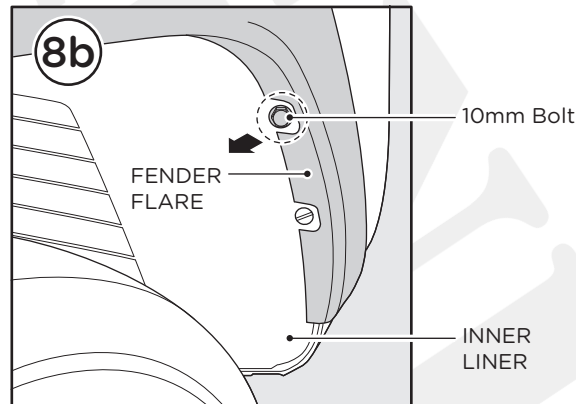
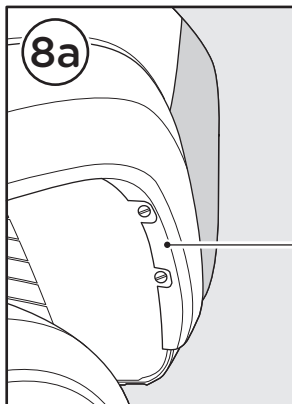

MAGNUM FRONT WINCH RT STYLE BUMPER

10. Using a Retainer Removal Tool, loosen and remove the six (6) factory bolts located on the top of the Bumper (10a) and bottom ends of the Bumper (10b). Pop the ends off the Inner Clip so you can pull the Bumper off and away from the vehicle. Place the Bumper on a soft, clean and flat surface.

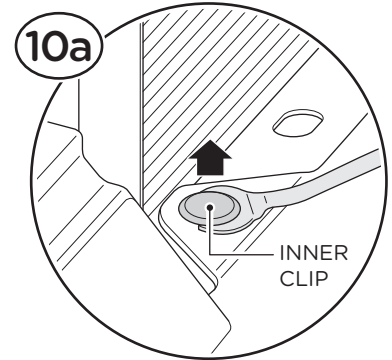
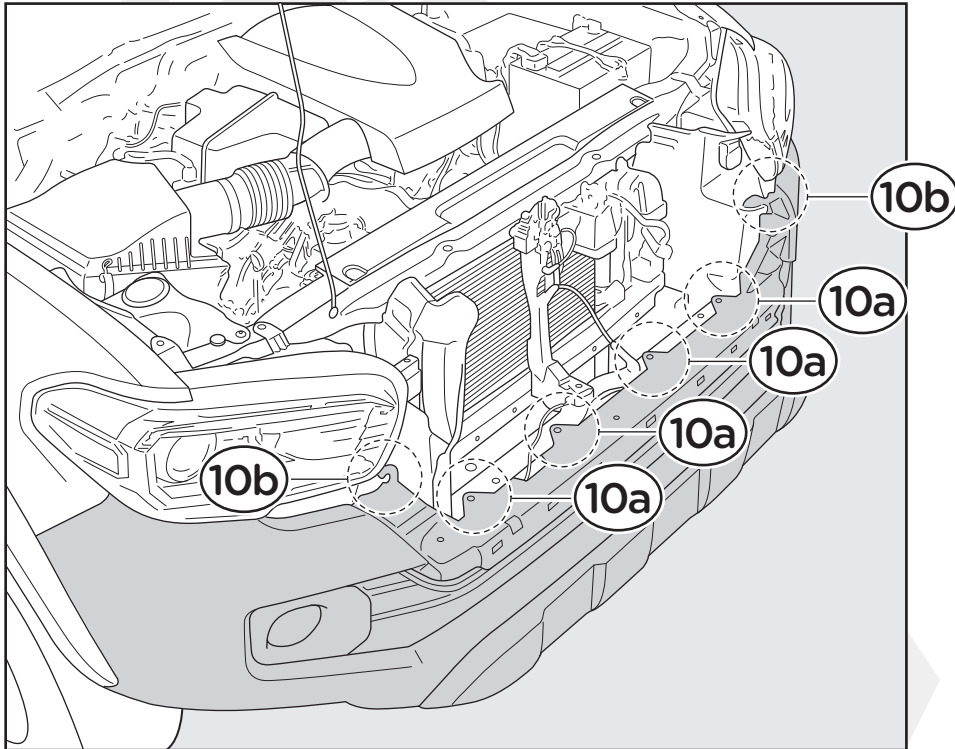

Top of Bumper

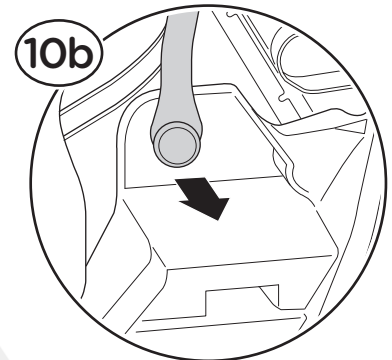

Bottom of Bumper

11. Remove the Plastic Impact Pad using flat-bladed screwdriver to pry pad from Aluminum Crossbar.

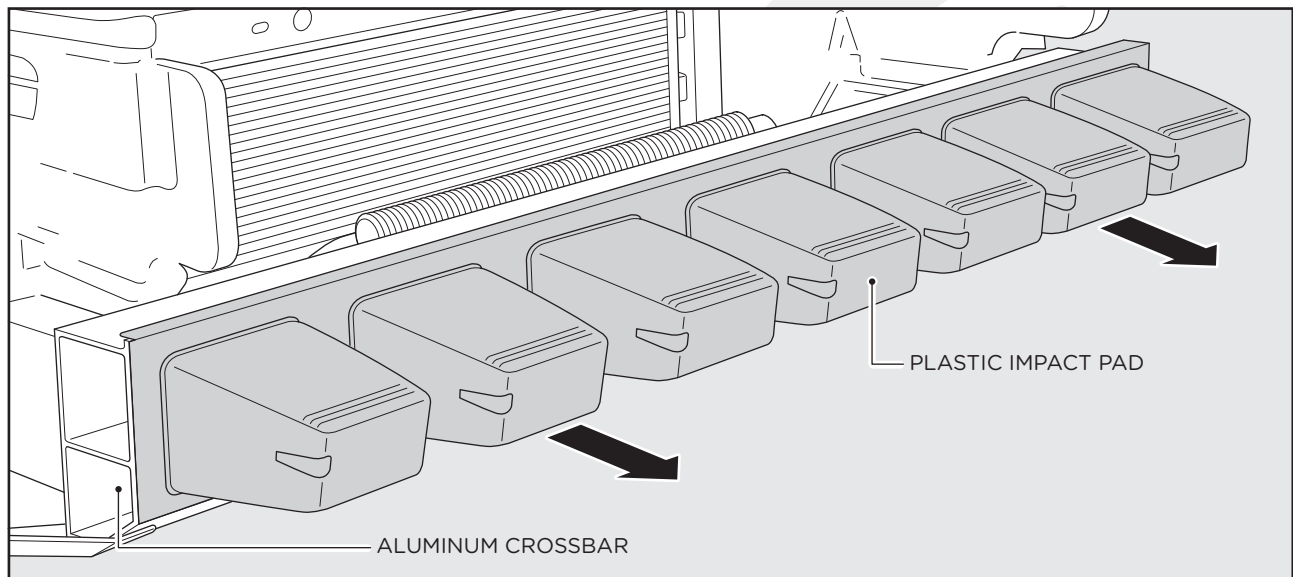

MAGNUM FRONT WINCH RT STYLE BUMPER

12. Locate and remove (3) Nuts on both the driver side (12a) and passenger side (12b) of Aluminum Cross Bar using a 14mm Deep Socket with extension. Remove Clip which attaches each Support Bar (located at each end of the Aluminum Cross Bar) to the Inner Liner (12c). Remove the Aluminum Cross Bar from the Studs located on the Frame (12d).

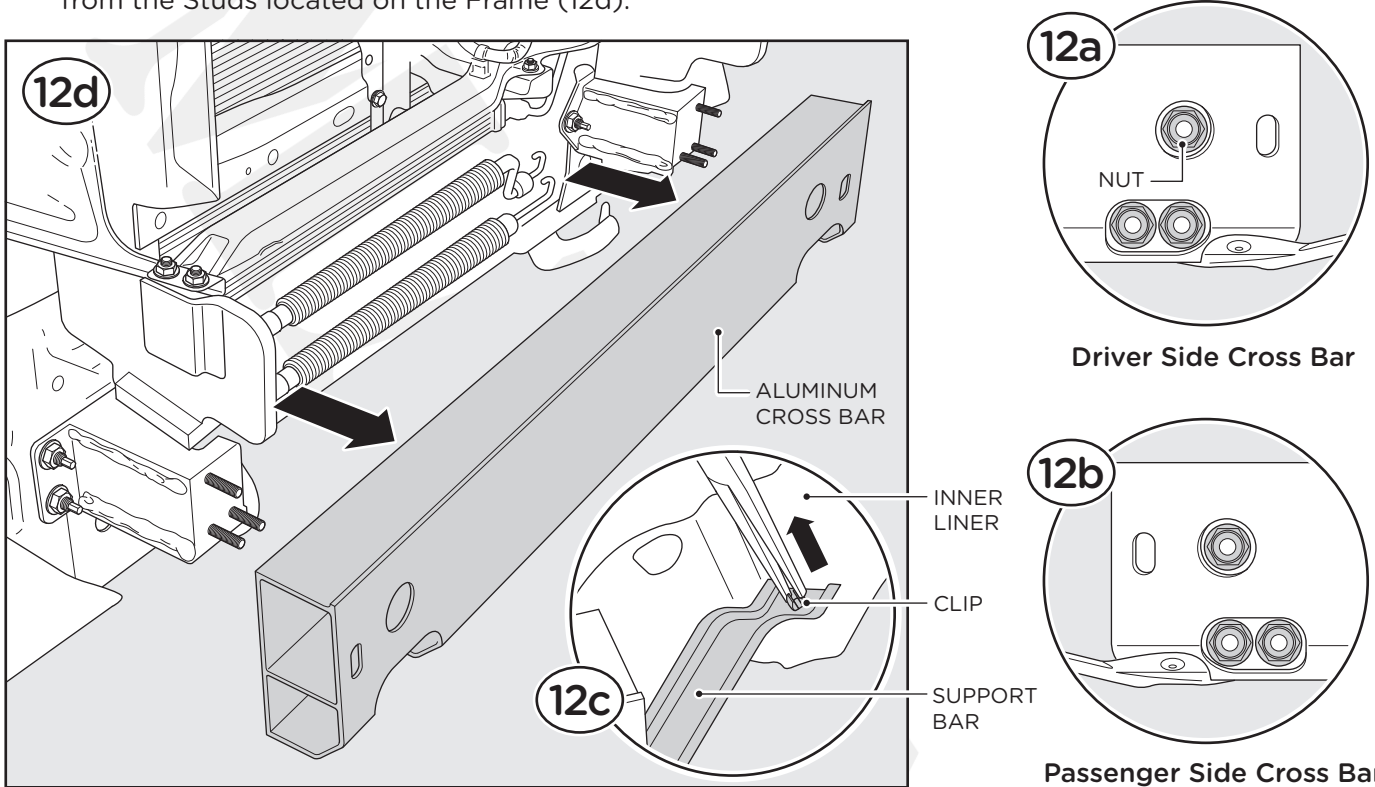

13. Using a 14mm deep socket with extension, remove the (3) Nuts from both the driver side Bracket (13a) and the passenger side Bracket (13b). Remove the Brackets from the Frame.
NOTE: Save the Flange Nuts for later use.

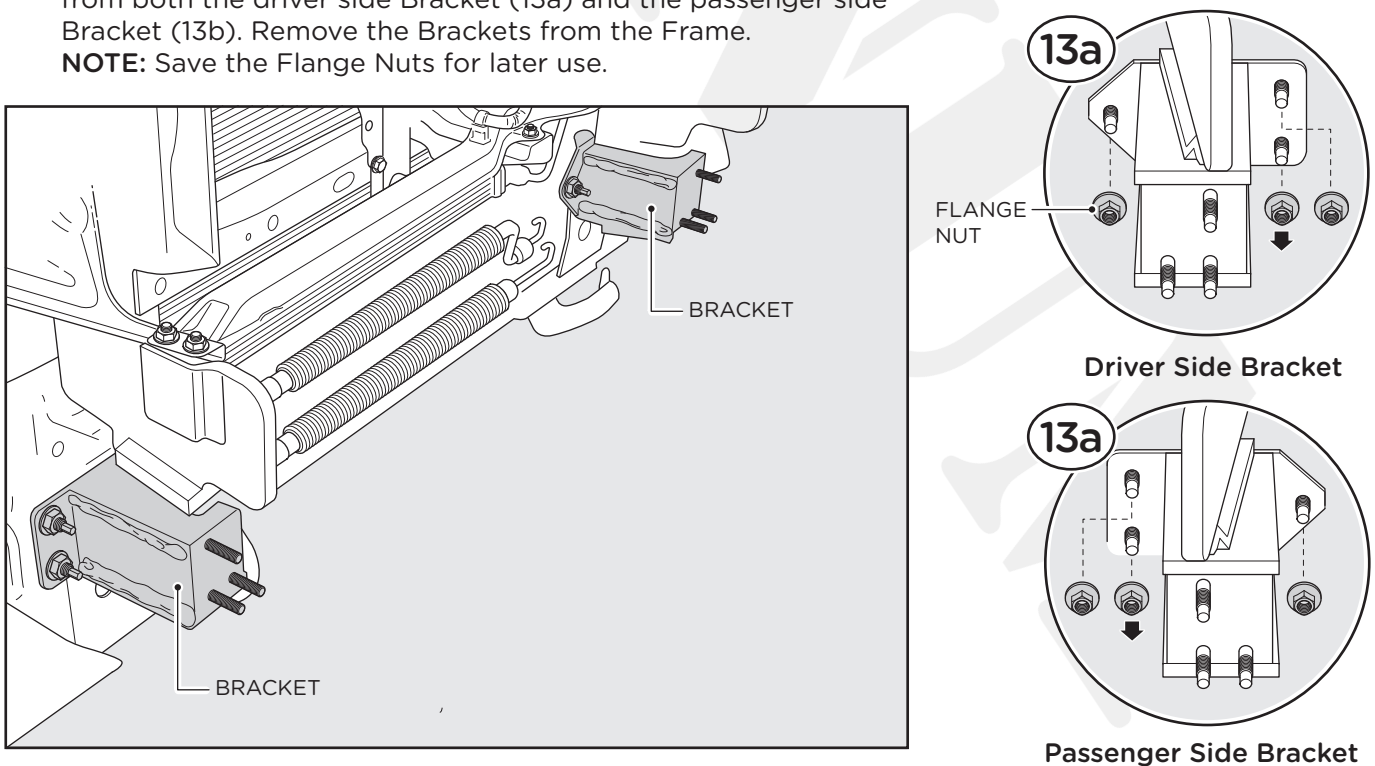

MAGNUM FRONT WINCH RT STYLE BUMPER

- 14.** If the vehicle is **NOT** equipped with a Power Steering Cooler, proceed to Step 17. For models equipped with a Power Steering Cooler, locate and temporarily remove the Hex Bolts (using a 12mm Wrench) attaching the Cooler to the top of the Front Cross Member, (1) on the passenger side (14a) and (1) on the driver side (14b). Locate the Passenger Side Inner Wheel Well. To make moving the cooler easier, remove the Inner Liner by first removing the 2 Retainer Clips (located on the right-hand side of the Inner Liner) using a Retainer Clip Removal Tool (14c). Peel back the Inner Liner to expose the 12mm Bolt. Remove the 12mm Bolt and Washer using a 12mm Socket (14d).

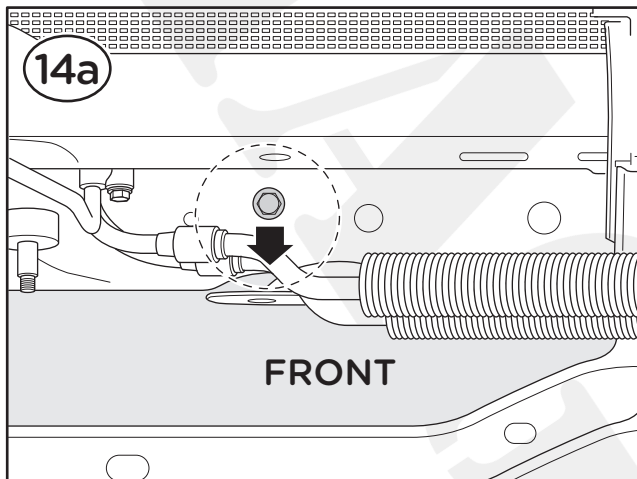

Top View Passenger Side

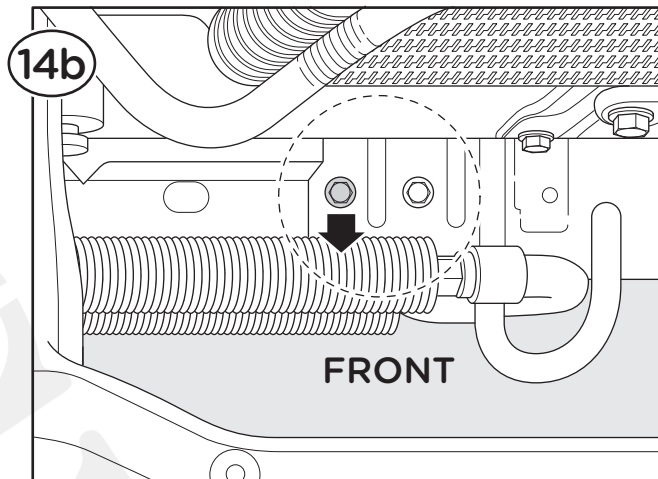

Top View Driver Side

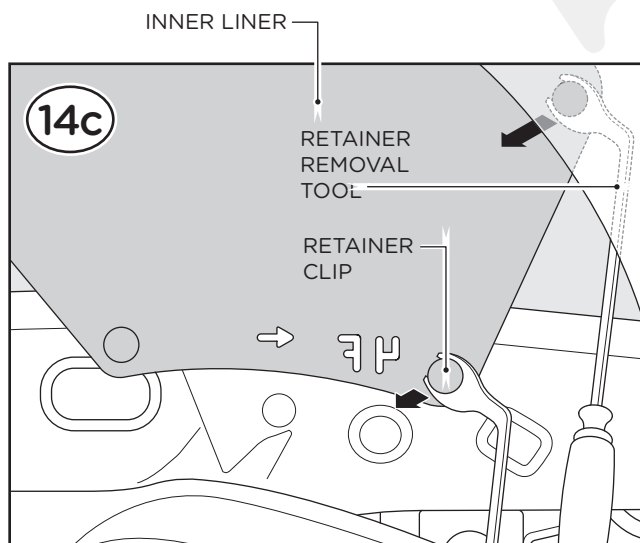

Passenger Side Inner Wheel Well

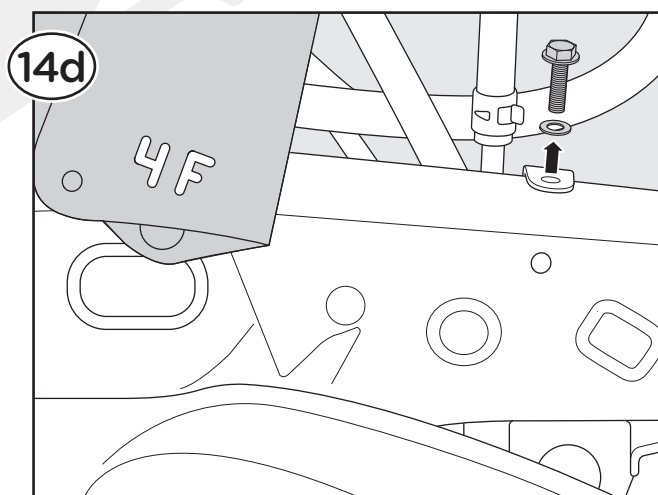

Passenger Side Inner Wheel Well

MAGNUM FRONT WINCH RT STYLE BUMPER

15. To reposition the Cooler, use (1) 8mm Bolt Plate. Make sure the Bolt Stud on the 8MM Bolt Plate is facing toward the Radiator. You will reuse the (1) Factory Bolt, Washer and Hex Nut to attach the Bolt Plate to the top of the Front Crosscross Member (Step 16). However, you must first insert the Factory Bolt and Washer into the end of the Bolt Plate while simultaneously securing an 8mm Flat Washer and 8mm Lock Nut onto the threaded Stud (using a 13mm Socket) at other end of Bolt Plate (15a). The result will be an assembly as shown (15b).

NOTE: If needed, use the included two (2) 8mm Hex Nuts as spacers to raise the Cooler for additional clearance.

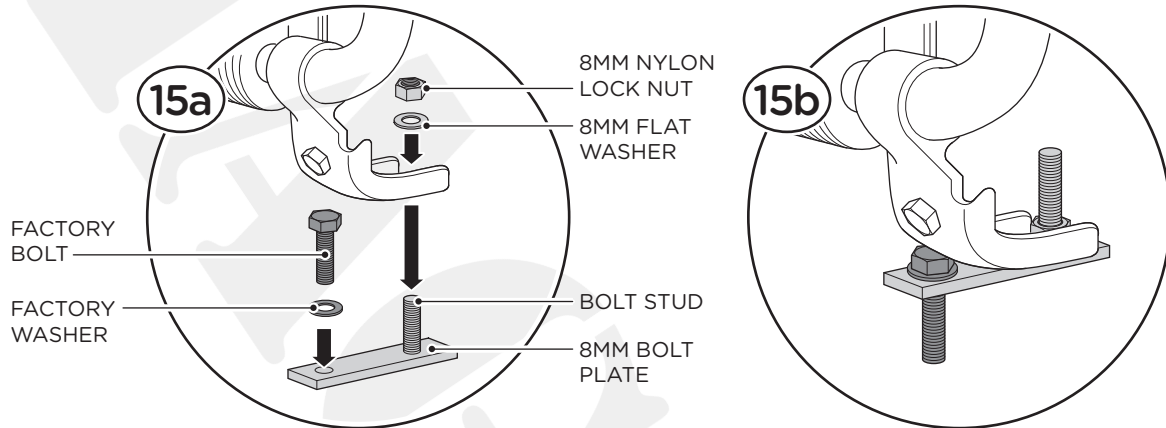

16. Lower Bolt Plate with Cooler attached onto Front Cross Member and secure Bolt Plate to the top of the Front Cross Member using (1) Factory Washer and (1) Factory Nut. Repeat Steps 15 and 16 for other end of Cooler.

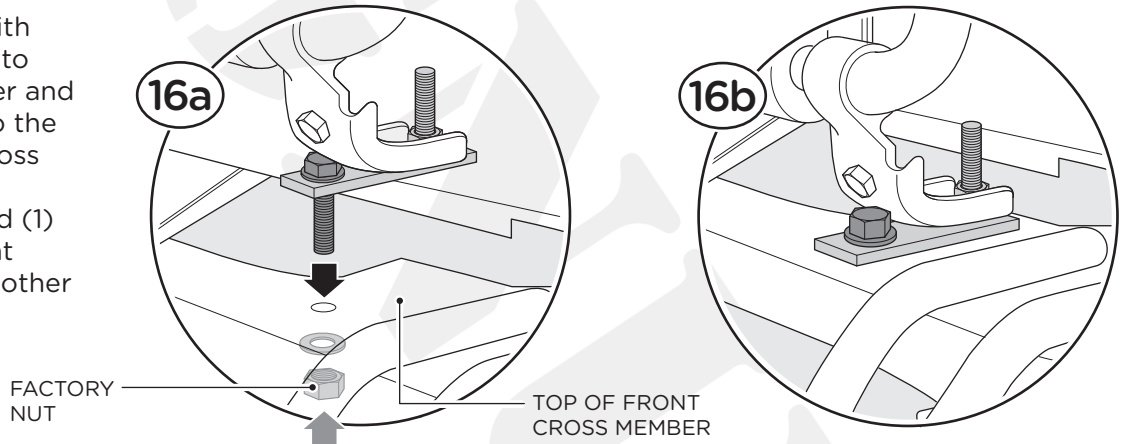

MAGNUM FRONT WINCH RT STYLE BUMPER

17. Remove the Plastic Center Pad from the Bumper.

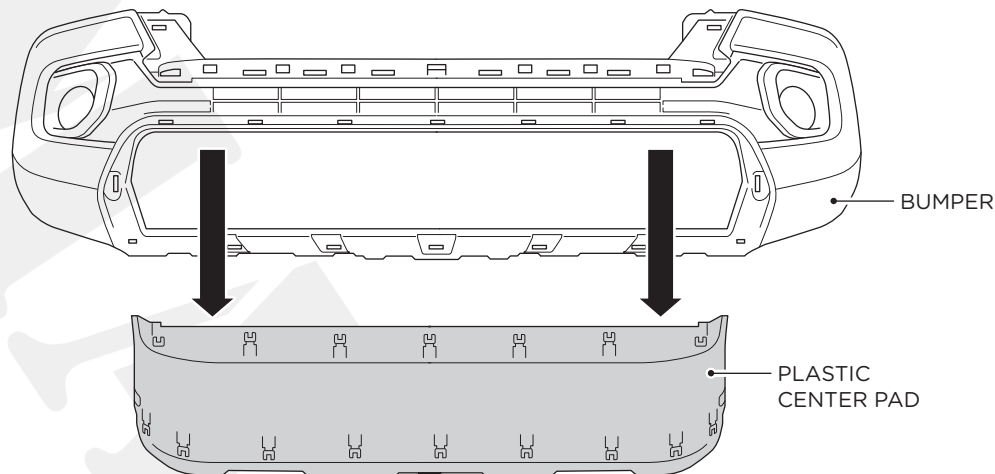

18. Using a Body Saw, carefully cut along the previously marked lines (18a).

IMPORTANT: For best fit, leave an extra 1/4" - 1/2" of material when cutting to make any adjustments at the end of the installation as necessary. Use an Angle Grinder to smooth out any rough edges caused by the cutting (18b).

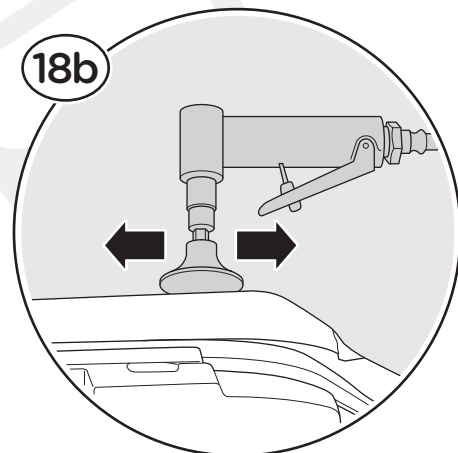
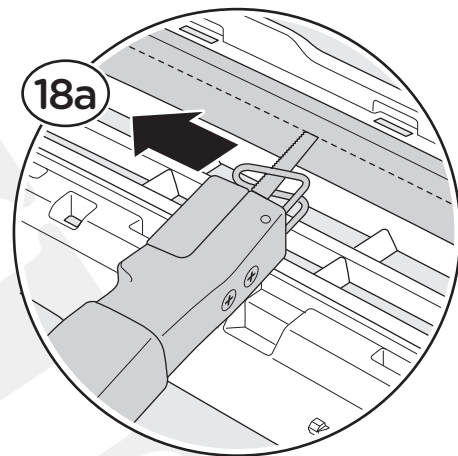
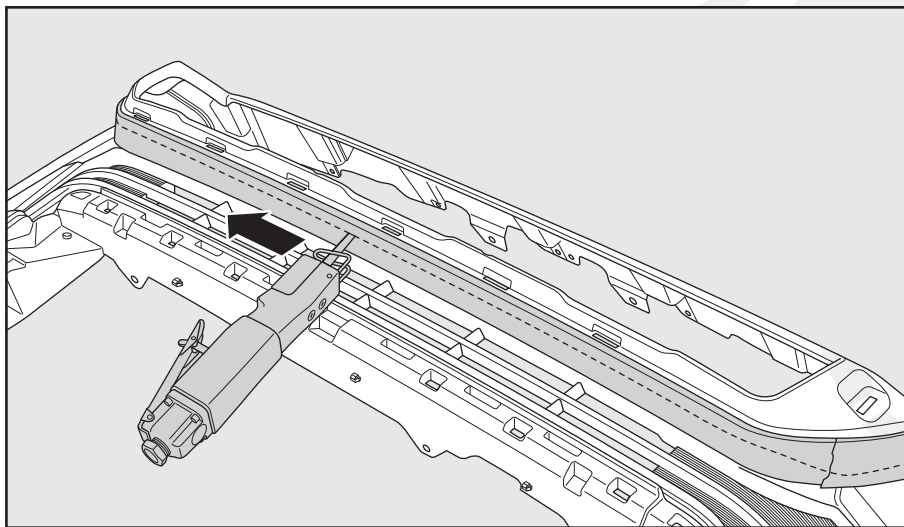

MAGNUM FRONT WINCH RT STYLE BUMPER

- 19.** Reinstall the cut Bumper. Next, hold the Front RT Bumper up and in place to check the fit of the against the cut Plastic Bumper and trim Plastic Bumper as necessary for best fit. Do not install the Front RT Bumper at this time, only check the fit against the Plastic Bumper.

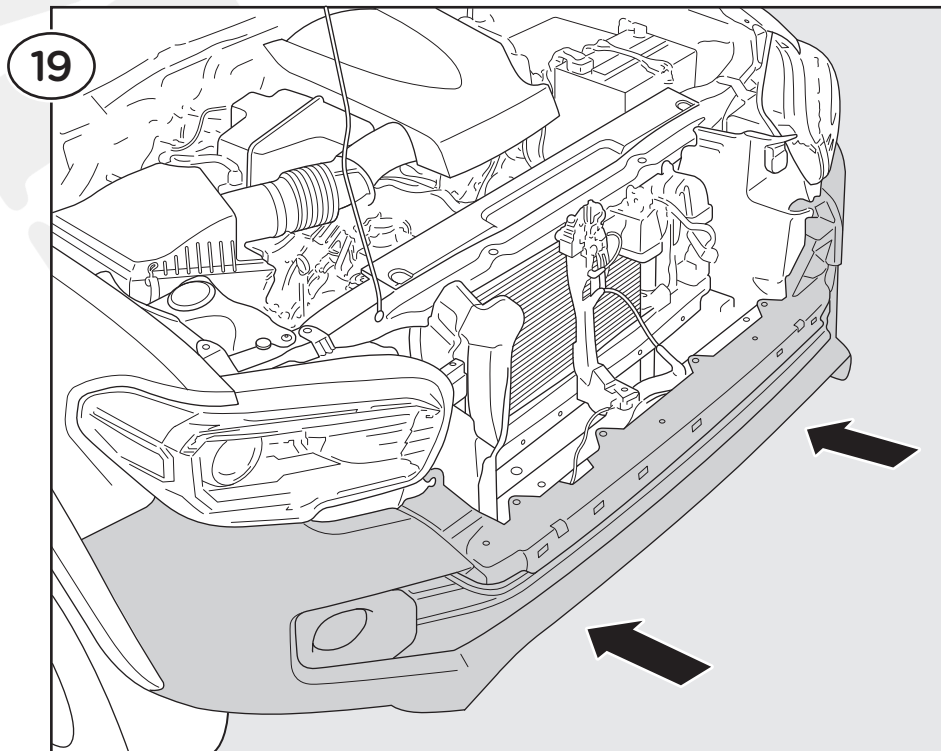

- 20.** Once all trimming is completed, cover the cut edge of the Plastic Bumper with the included Edge Trim (20a). Cut the Edge Trim to fit as required (20b). Reattach the Fender Flares and Fog Light Wiring Harness at this time.

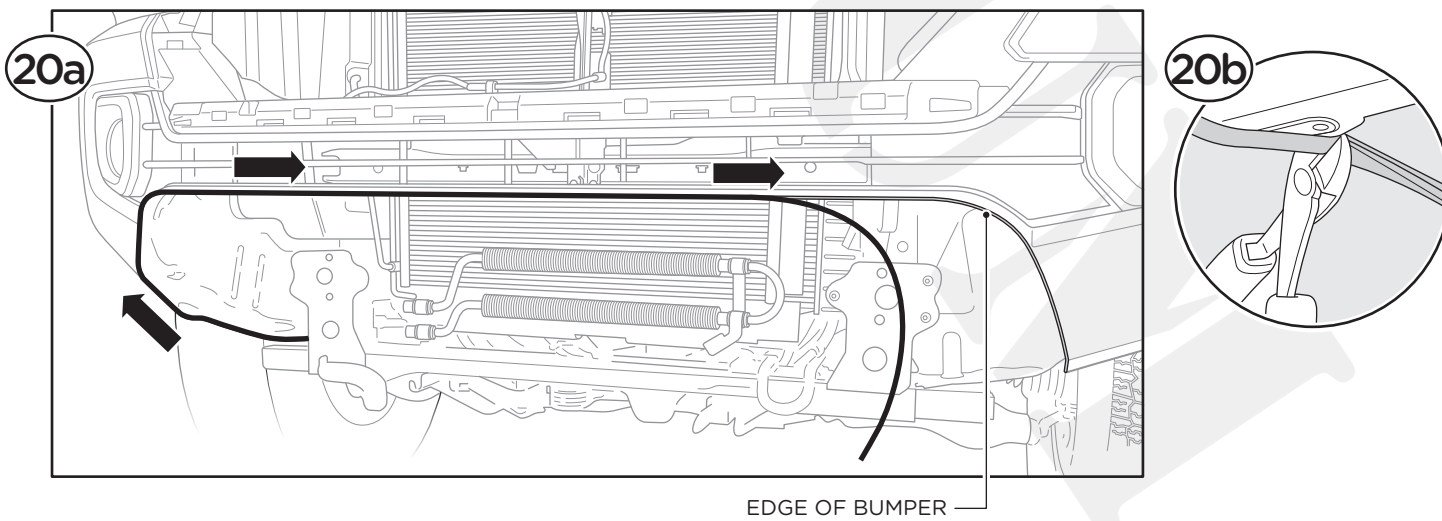

MAGNUM FRONT WINCH RT STYLE BUMPER

21. Next, move the RT Front Bumper to a stable, clean and flat surface.

22. Center LED Light installation (sold separately).

- Attach each "L" Light Brackets to the mounting tabs on the back of the Front Bumper using the provided (1) 8mm x 25mm Hex Bolt, (2) 8mm x 24mm Flat Washers and (1) 8mm Nylon Lock Nut per "L" Bracket. Leave hardware loose.
- Attach the LED Light assembly to the "L" Brackets.
- After adjusting the Light as necessary, tighten hardware.
- Connect the Wire Harness to the vehicle by following the instructions included with the Light.

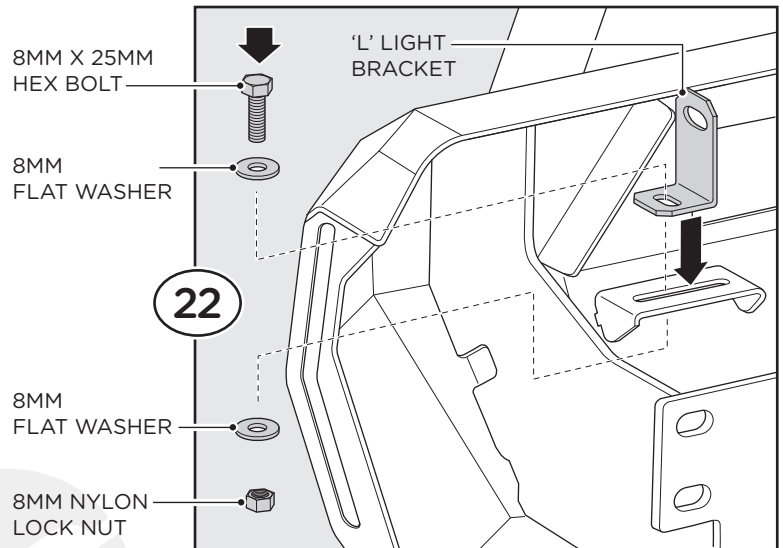

23. With assistance, position the RT Front Bumper so it aligns with Frame Bracket Studs. Temporarily support the weight of the Bumper.

WARNING: To avoid possible injury or damage to the vehicle, do not proceed until the Bumper is fully and safely supported.

24. In order to reach the other side you may have to remove the indicated Shroud. Remove 2 Retainer Clips by prying with a Retainer Clip Removal Tool for one of the clips and a pair of Needle Nose Pliers for the other Clip.

Note: The Retainer Clip that is removed with the Needle Nose Pliers is hidden behind the frame.

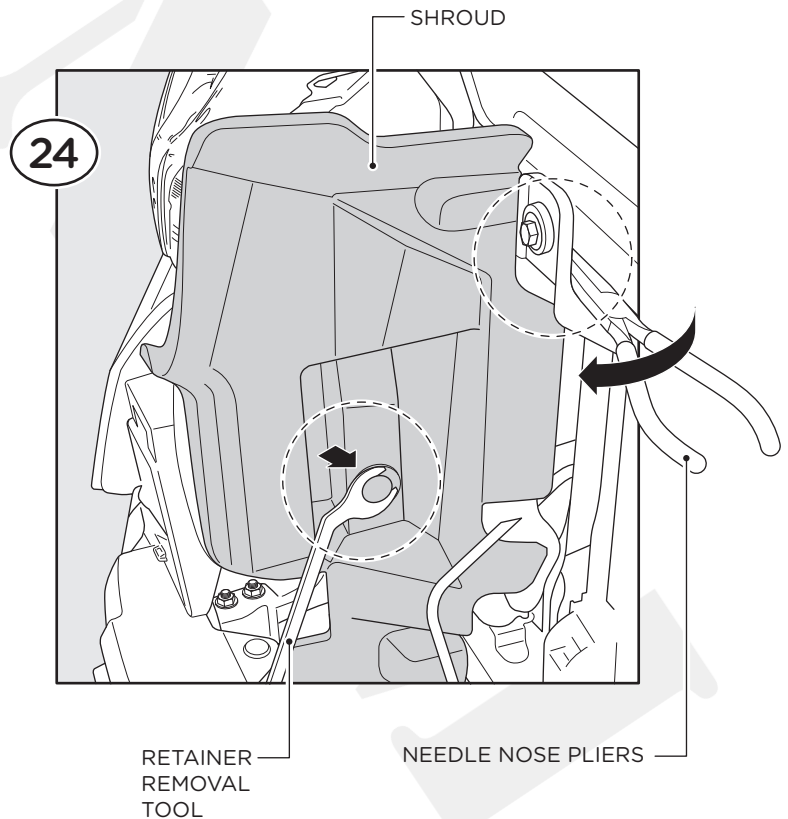

MAGNUM FRONT WINCH RT STYLE BUMPER

Note: To install RT Front Bumper please refer to the simplified diagram below.

25. Reuse the (6) Factory Flange Nuts to attach the Front Bumper Assembly to the Frame Bracket Stud. Three (3) Factory Flange Nuts will be user per each set of studs. Leave hardware loose at this time.

a. Check to make sure RT Front Bumper and the trimmed Plastic Bumper fit properly. Trim Plastic Bumper Cover if needed. Level and adjust the RT Front Bumper as needed and tighten all six (6) factory Hex Nuts.

26. Next, attach the driver side corner of the Winch Tray to the hole in the Frame with (1) 18mm x 120mm Long Hex Bolt, (2) 12mm Flat Washers and (1) 12mm Nylon Lock Nut. Tighten using an 18mm Open End Wrench and a 19mm Socket for the Frame Bolt.

Repeat to attach the passenger side of the Winch Tray to the Frame. Fully tighten hardware at this time.

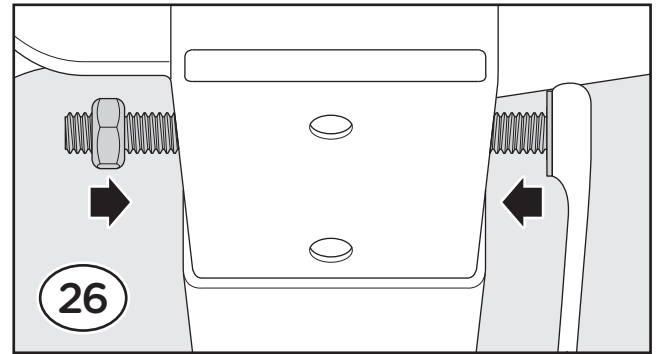

Side View of Frame

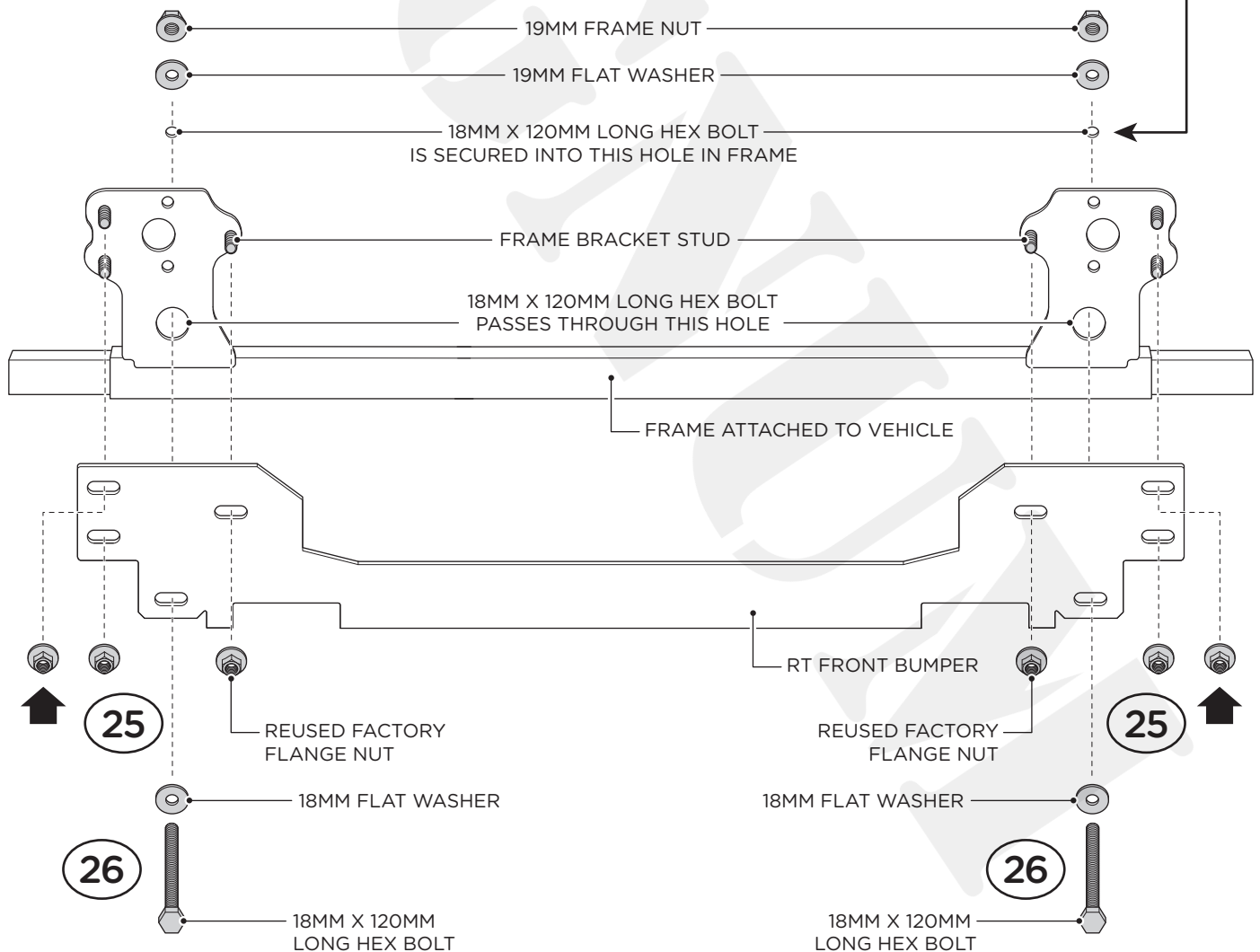

MAGNUM FRONT WINCH RT STYLE BUMPER

- 26.** Reinstall the Grille and top plastic cover.
- 27.** Reinstall the skid plate, if equipped.
- 28.** Do periodic inspections to the installation to make sure that all hardware is secure and tight.