

BRACKET KIT INSTALLATION

SKU# RB-0200-BK



COMPONENTS		HARDWARE	
<p>DRIVER SIDE</p> <p>Qty: 1 Front Bracket</p> <p>Qty: 1 Center Bracket</p> <p>Qty: 1 Rear Bracket</p> <p>Qty: 2 Front & Center Support Brace</p> <p>Qty: 1 Rear Support Brace</p>	<p>PASSENGER SIDE</p> <p>Qty: 1 Front Bracket</p> <p>Qty: 1 Center Bracket</p> <p>Qty: 1 Rear Bracket</p> <p>Qty: 2 Front & Center Support Brace</p> <p>Qty: 1 Rear Support Brace</p>	<p>Qty: 18 M8 x 30MM Hex Head Bolts</p> <p>Qty: 6 M8 x 35MM Hex Head Bolts</p> <p>Qty: 6 M8 Bolt+M8 Nut Plate</p>	<p>Qty: 60 M8 Flat Washers</p> <p>Qty: 42 M8 Lock Washers</p> <p>Qty: 36 M8 Hex Head Nuts</p> <p>Qty: 6 Plastic Retainer</p>
TOOLS REQUIRED		INSTALLATION NOTES	
<p>RATCHET</p> <p>TORQUE WRENCH</p> <p>13MM SOCKET</p>	<p>NOTE: Center Bracket & Brace is NOT used on Regular Cab Models</p> <p>TORQUE NOTE: Bolts and nuts should be torqued to 15-20 ft lbs.</p> <p>NOTE: Hardware for Board Installation is included.</p> <p>NOTE: Some spare hardware is included.</p>		

Remove all contents from the package and check brackets for any damage. Also, verify that all components and hardware listed above are included before you begin installation. If anything is missing or damaged please contact us at customerservice@raptorseries.com

Read through entire installation manual and installation drawings to ensure that you understand all of the components and hardware before proceeding with installation.

NOTE: When installing the brackets, all hardware must be left loose until all of the items are attached.

Locate factory hole locations in three (3) places per side on the body mount.

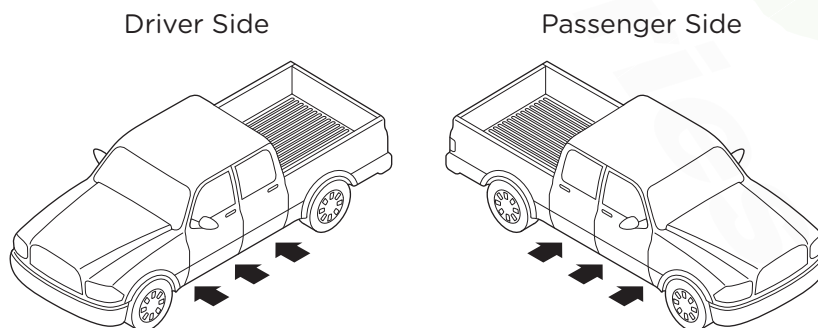

BRACKET ORIENTATION

DRIVER SIDE

Raptor
Series

NOTE: Center Bracket & Brace is NOT used on Regular Cab Models

1. Begin installation on driver side. Position the Front Bracket, Center Bracket and Rear Bracket as shown in diagram.

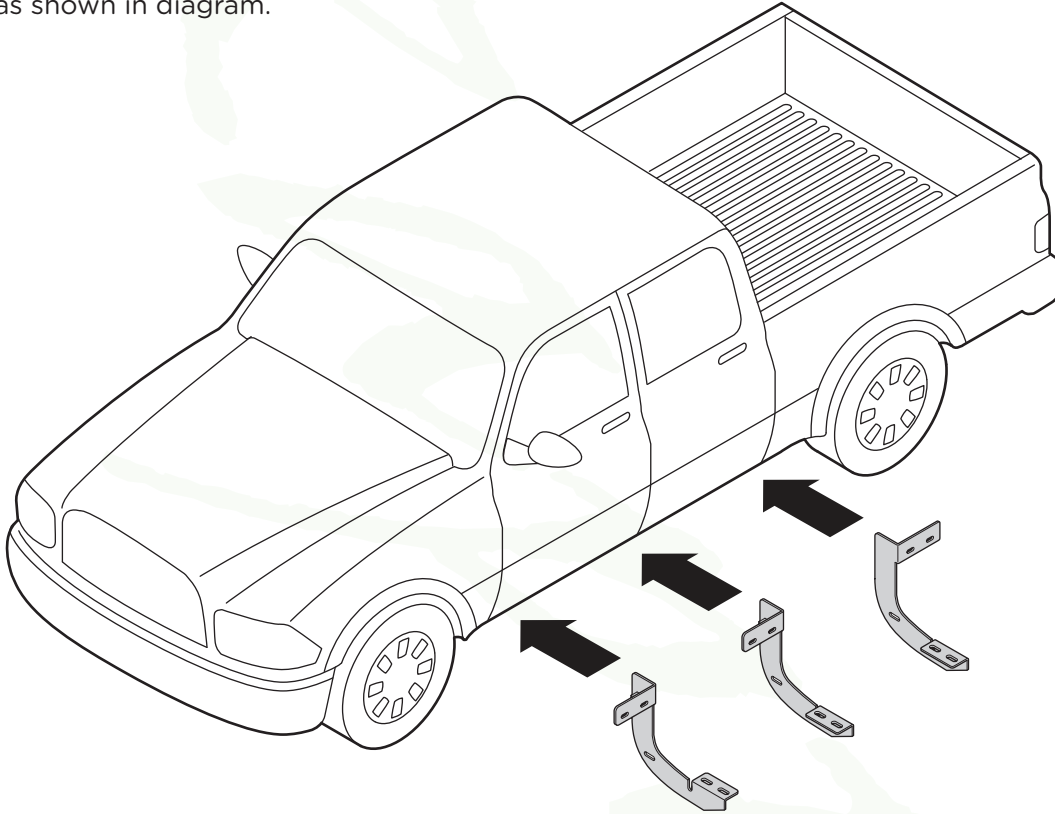

2. Driver Side Front Bracket cradle (2a) will face to the rear of the truck. Driver Side Center (2b) and Rear Bracket cradles (2c) will face toward the front of the truck.

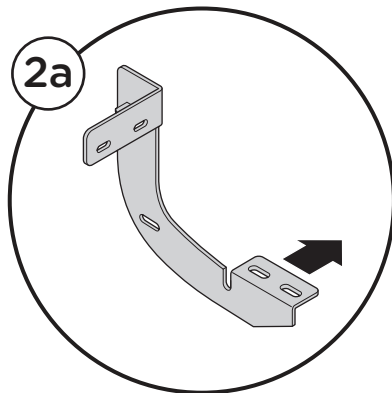

Driver Side
Front Bracket

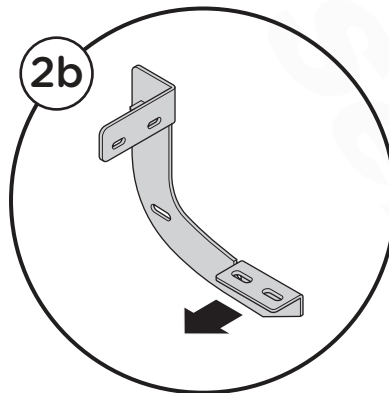

Driver Side
Center Bracket

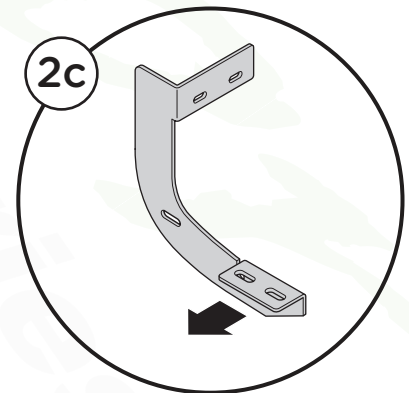

Driver Side
Rear Bracket

BRACKET INSTALLATION (WITH THREADED INSERTS)

DRIVER SIDE



If threaded inserts already exist in your rocker panel holes, proceed with Step 3.
If threaded inserts do not exist in your rocker panel holes, skip to Step 6 on Page 4.

- 3.** Fasten the top portion of the Driver Side Front Bracket by using (2) M8 x 30MM Hex Head Bolts, (2) M8 Flat Washers and (2) M8 Lock Washers.

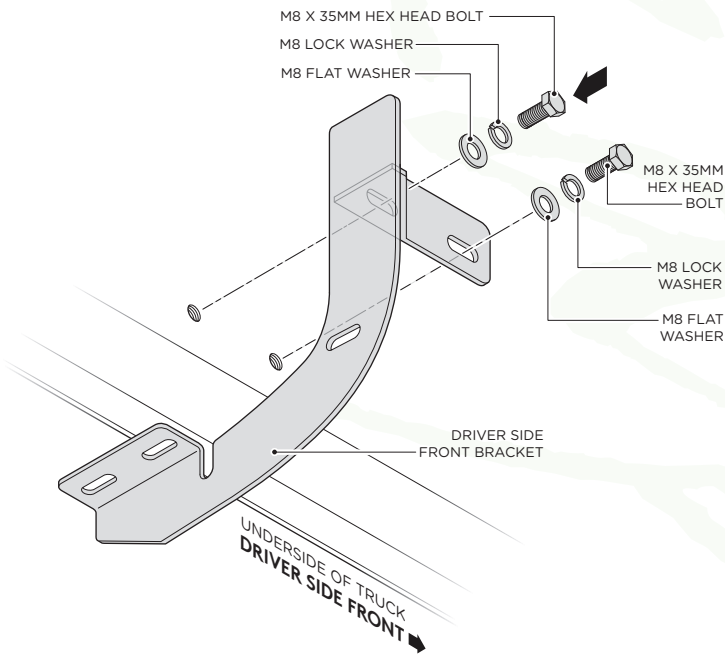

- 4.** Fasten the top portion of the Driver Side Center Bracket by using (2) M8 x 30MM Hex Head Bolts, (2) M8 Flat Washers and (2) M8 Lock Washers.

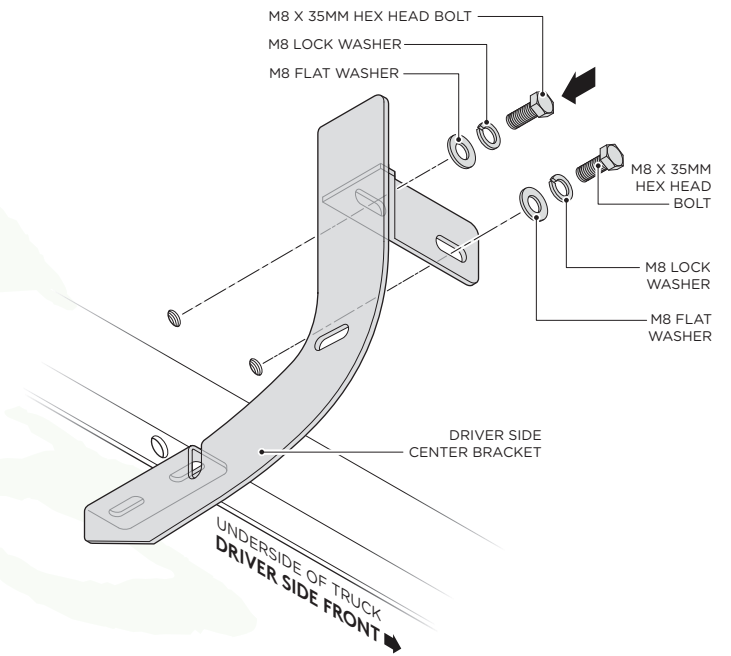

- 5.** Fasten the top portion of the Driver Side Rear Bracket by using (2) M8 x 30MM Hex Head Bolts, (2) M8 Flat Washers and (2) M8 Lock Washers.

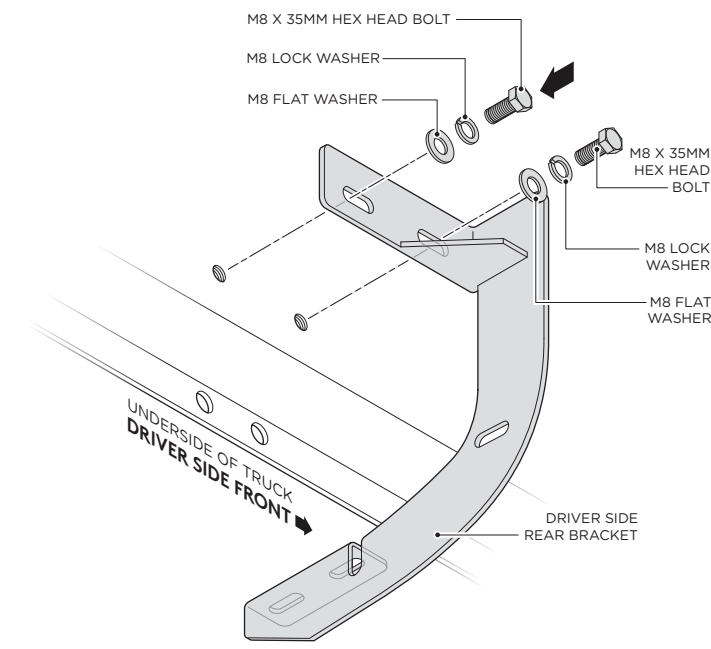

M8 BOLT + M8 NUT PLATE INSTALLATION

DRIVER SIDE



If threaded inserts do not exist in your rocker panel holes, proceed with Step 6.

NOTE: Removal of tape or plastic plugs may be needed to expose factory holes.

NOTE: Use caution to not drop any hardware into your rocker panel!

6. Follow the steps shown below to install the M8 Bolt + M8 Nut Plate.

Insert M8 Bolt + M8 Nut Plate into top hole as shown.

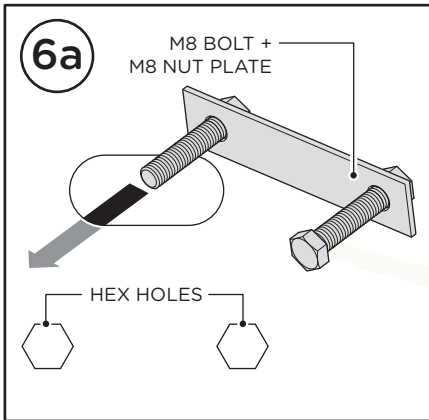

Rotate the threaded side of the M8 Bolt + M8 Nut Plate to the bottom left hole.

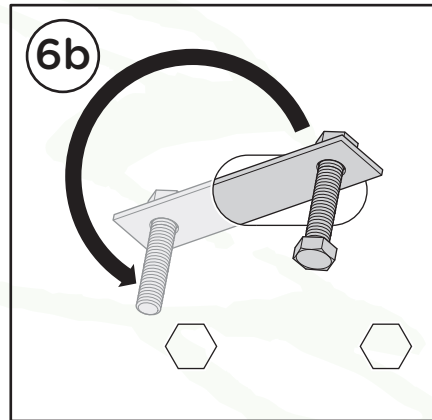

Pull the threaded side of the M8 Bolt + M8 Nut Plate through the bottom left hole.

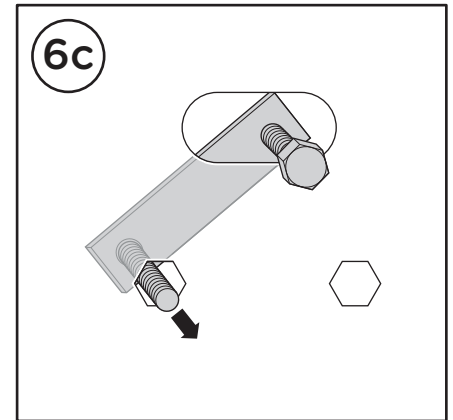

Install Plastic Retainer to ensure you do not drop the M8 Bolt + M8 Nut Plate into the rocker panel.

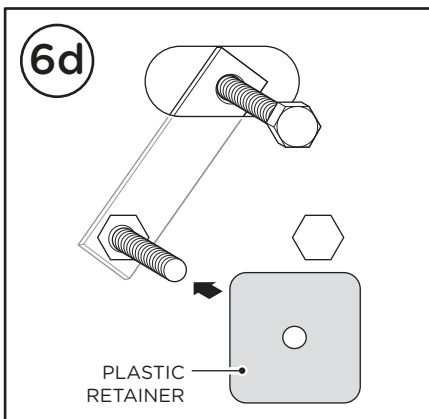

Remove the M8 Bolt from the M8 Nut Plate.

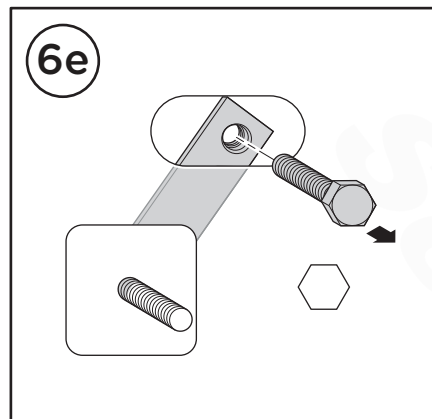

The M8 Nut Plate will now be able to rotate down to the hole in the rocker panel, allowing for bracket installation.

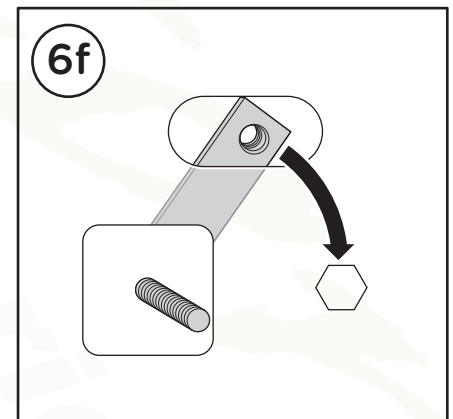

BRACKET INSTALLATION (WITHOUT THREADED INSERTS)

DRIVER SIDE



- 7.** Fasten the top portion of the Driver Side Front Bracket to the bolt side of the M8 Bolt + M8 Nut Plate by using (1) M8 Flat Washer, (1) M8 Lock Washer and (1) M8 Hex Head Nut. Next, install the (1) M8 x 35MM Hex Head Bolt, (1) M8 Lock Washer and (1) M8 Flat Washer to the nut side of the M8 Bolt + M8 Nut Plate.

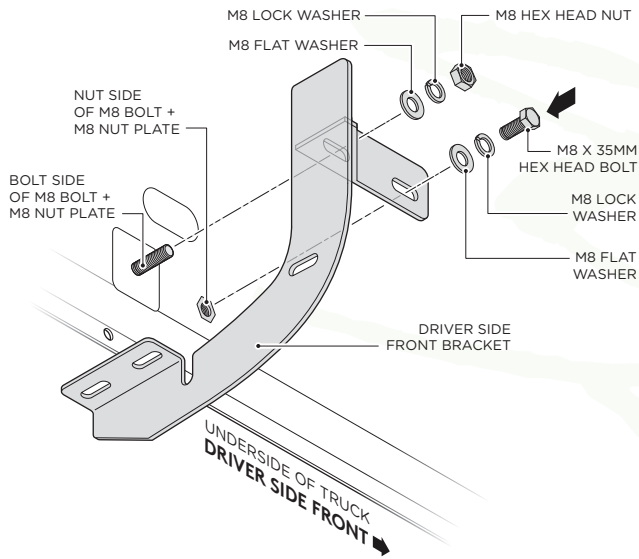

- 8.** Fasten the top portion of the Driver Side Center Bracket to the bolt side of the M8 Bolt + M8 Nut Plate by using (1) M8 Flat Washer, (1) M8 Lock Washer and (1) M8 Hex Head Nut. Next, install the (1) M8 x 35MM Hex Head Bolt, (1) M8 Lock Washer and (1) M8 Flat Washer to the nut side of the M8 Bolt + M8 Nut Plate.

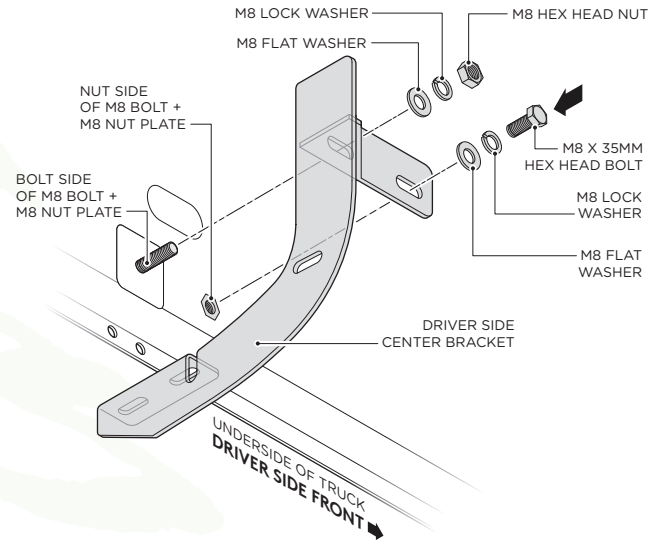

NOTE: NOT used on Regular Cab Models

- 9.** Fasten the top portion of the Driver Side Rear Bracket to the bolt side of the M8 Bolt + M8 Nut Plate by using (1) M8 Flat Washer, (1) M8 Lock Washer and (1) M8 Hex Head Nut. Next, install the (1) M8 x 35MM Hex Head Bolt, (1) M8 Lock Washer and (1) M8 Flat Washer to the nut side of the M8 Bolt + M8 Nut Plate.

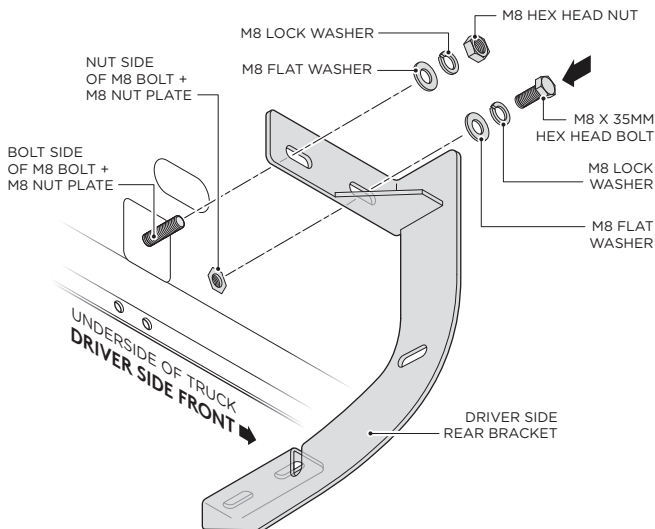

SUPPORT BRACE INSTALLATION

DRIVER SIDE

Raptor
Series

- 10.** Fasten the top of the Driver Side Front Support Brace to the rocker panel using (2) M8 x 30MM Hex Head Bolts, (2) M8 Flat Washers, (2) M8 Lock Washers and (2) M8 Hex Head Nuts. Then, fasten the bottom of the Driver Side Front Support Brace to the Driver Side Front Bracket using (1) M8 x 30MM Hex Head Bolt (2) M8 Flat Washers, (1) M8 Lock Washer and (1) M8 Hex Head Nut.

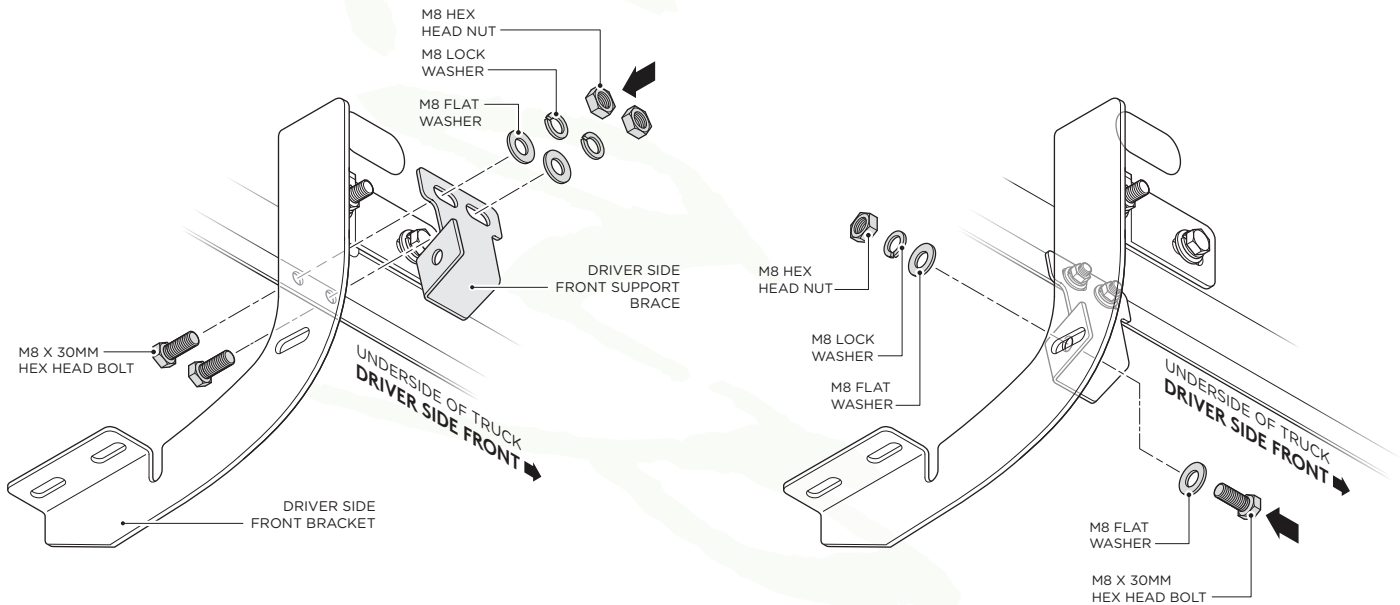

- 11.** Fasten the top of the Driver Side Center Support Brace to the rocker panel using (2) M8 x 30MM Hex Head Bolts, (2) M8 Flat Washers, (2) M8 Lock Washers and (2) M8 Hex Head Nuts. Then, fasten the bottom of the Driver Side Center Support Brace to the Driver Side Center Bracket using (1) M8 x 30MM Hex Head Bolt (2) M8 Flat Washers, (1) M8 Lock Washer and (1) M8 Hex Head Nut.

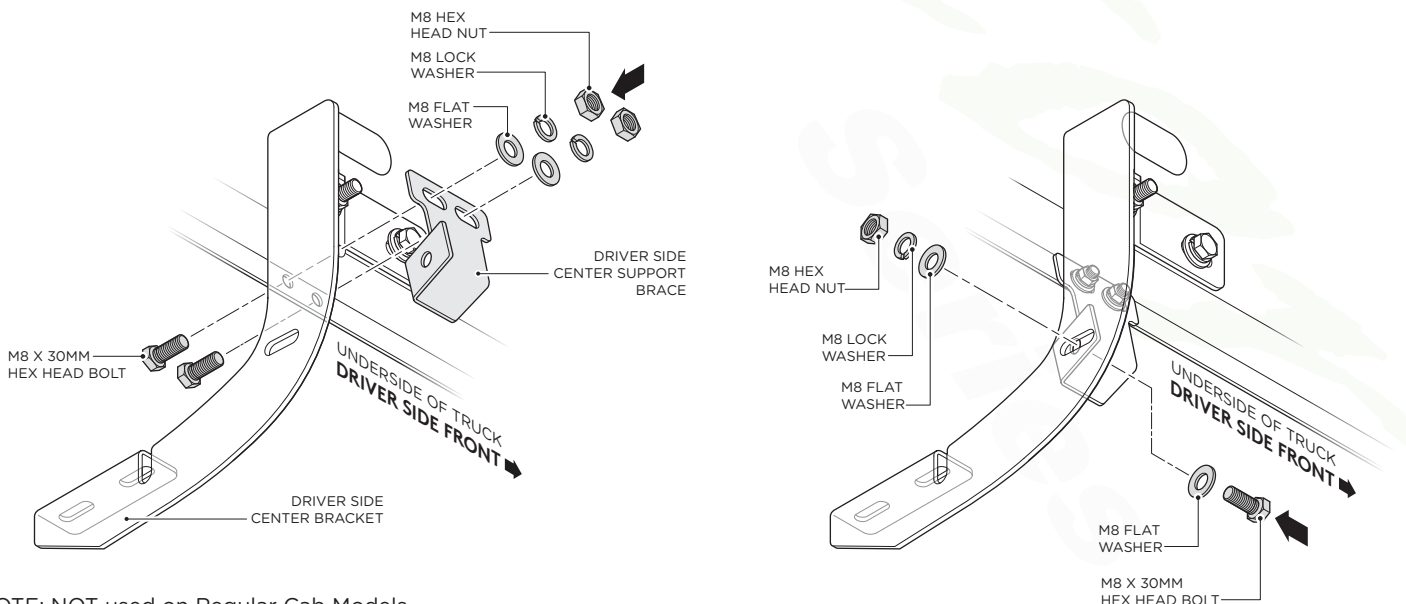

NOTE: NOT used on Regular Cab Models

SUPPORT BRACE INSTALLATION

DRIVER SIDE

Raptor
Series

- 12.** Fasten the top of the Driver Side Rear Support Brace to the rocker panel using (2) M8 x 30MM Hex Head Bolts, (2) M8 Flat Washers, (2) M8 Lock Washers and (2) M8 Hex Head Nuts. Then, fasten the bottom of the Driver Side Rear Support Brace to the Driver Side Rear Bracket using (1) M8 x 30MM Hex Head Bolt (2) M8 Flat Washers, (1) M8 Lock Washer and (1) M8 Hex Head Nut.

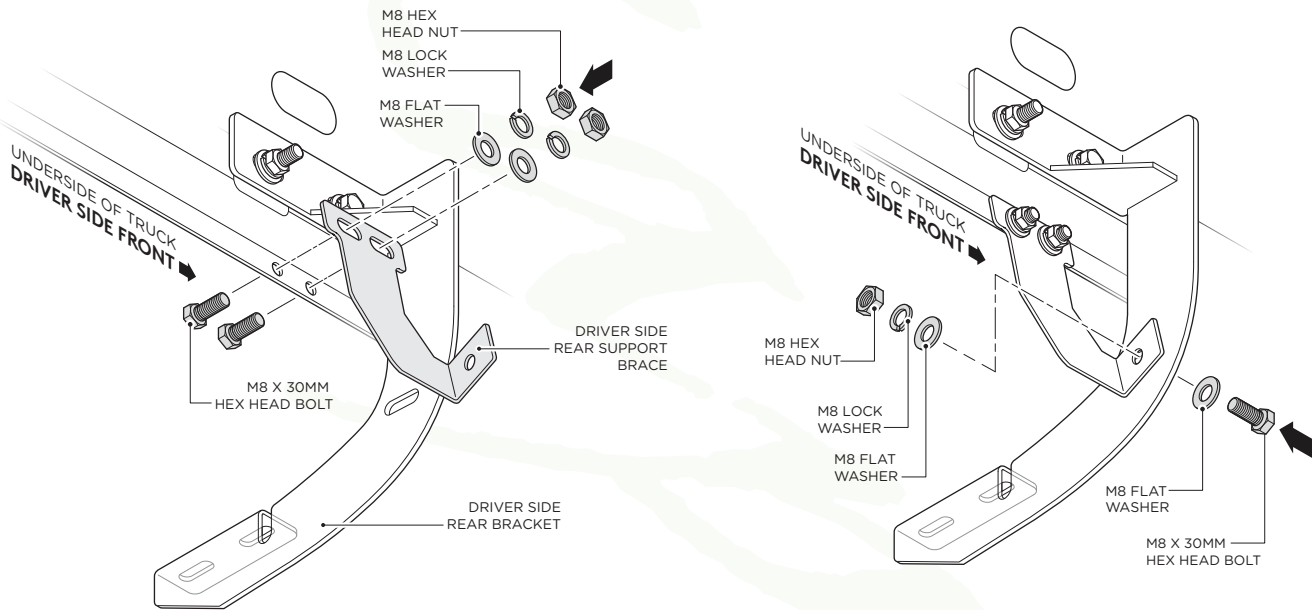

RUNNING BOARD INSTALLATION

DRIVER SIDE



NOTE: Before proceeding to Step 13 see pages 16, 17, 18 for Board Installation Setup.

- 13.** Fasten the Running Board to the Driver Side Front Bracket cradle by using (2) M8 Flat Washers, (2) M8 Lock Washers and (2) M8 Hex Head Nuts.

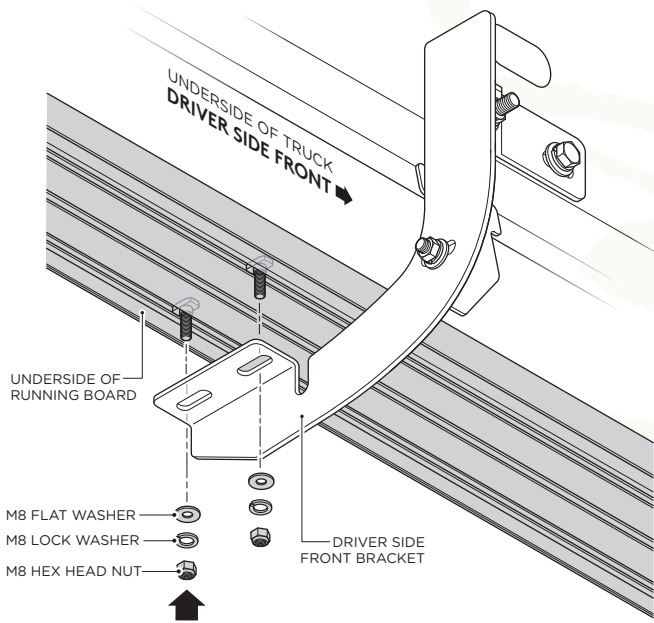

- 14.** Fasten the Running Board to the first Driver Side Center Bracket cradle by using (2) M8 Flat Washers, (2) M8 Lock Washers and (2) M8 Hex Head Nuts.

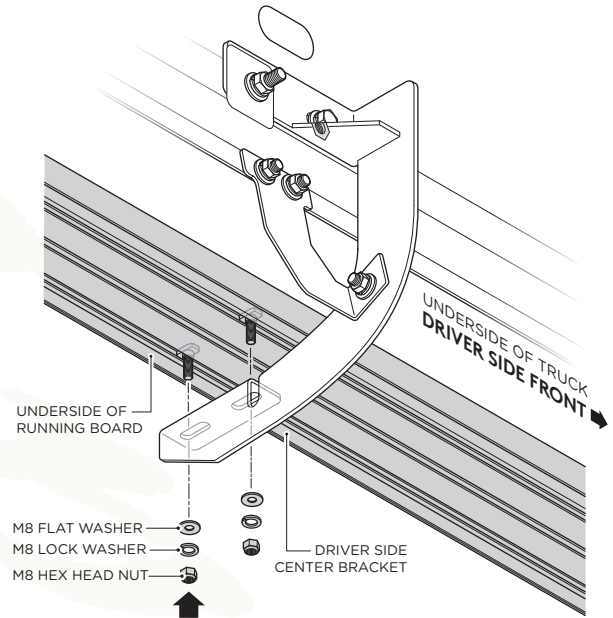

- 15.** Fasten the Running Board to the Driver Side Rear Bracket cradle by using (2) M8 Flat Washers, (2) M8 Lock Washers and (2) M8 Hex Head Nuts.

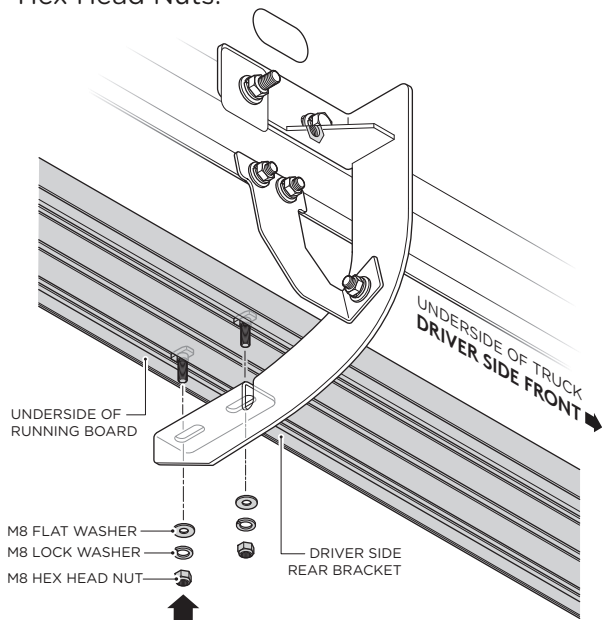

BRACKET ORIENTATION

PASSENGER SIDE

Raptor
Series

NOTE: Center Bracket & Brace is NOT used on Regular Cab Models

1. Begin installation on passenger side. Position the Front Bracket, Center Bracket and Rear Bracket as shown in diagram.

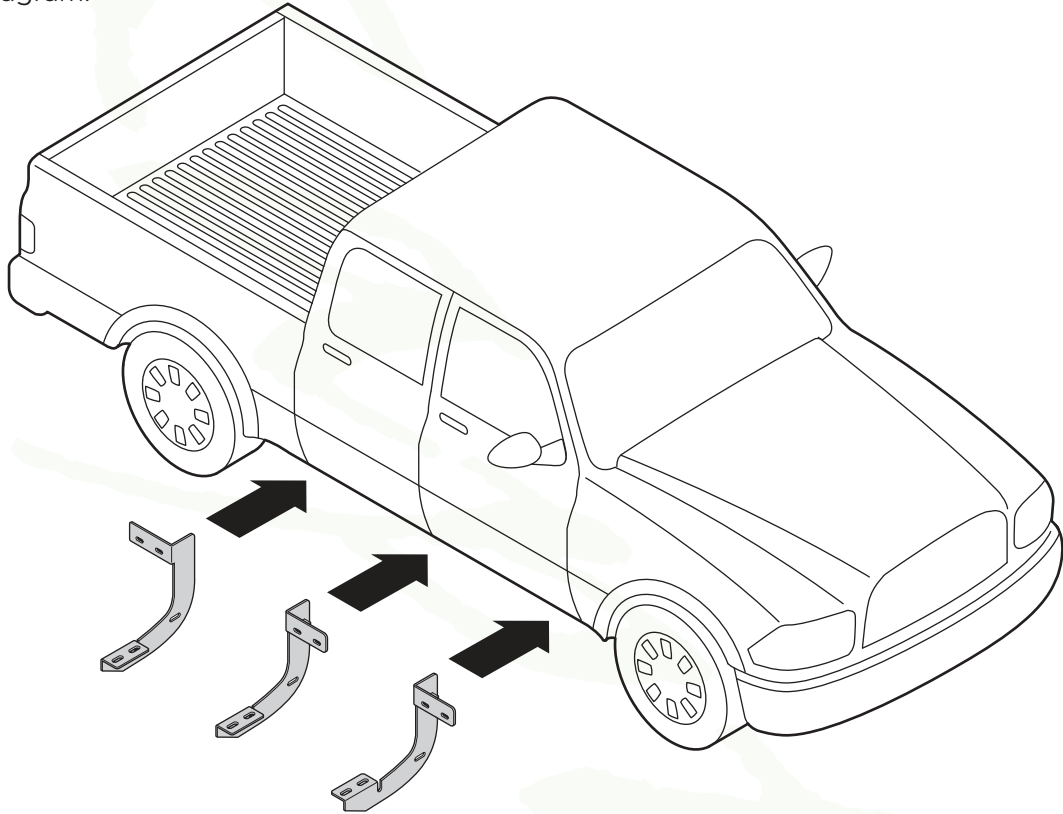

2. Passenger Side Front Bracket cradle (2a) will face to the rear of the truck. Passenger Side Center (2b) and Rear Bracket cradles (2c) will face toward the front of the truck.

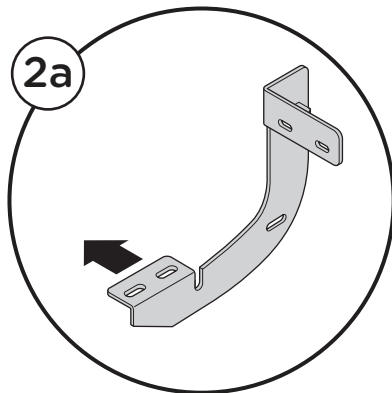

Passenger Side
Front Bracket

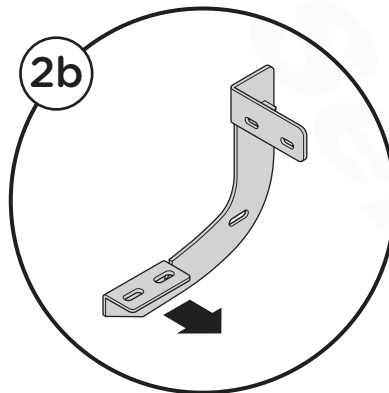

Passenger Side
Center Bracket

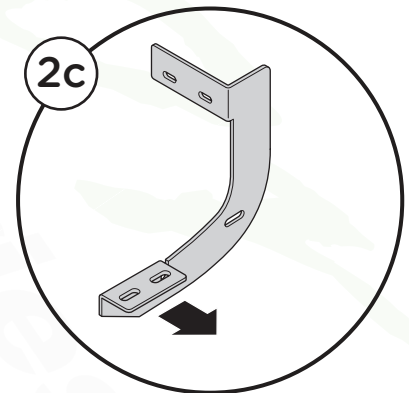

Passenger Side
Rear Bracket

BRACKET KIT INSTALLATION (WITH THREADED INSERTS)

PASSENGER SIDE



If threaded inserts already exist in your rocker panel holes, proceed with Step 3.
If threaded inserts do not exist in your rocker panel holes, skip to Step 6 on page 10.

- 3.** Fasten the top portion of the Passenger Side Front Bracket by using (2) M8 x 30MM Hex Head Bolts, (2) M8 Flat Washers and (2) M8 Lock Washers.

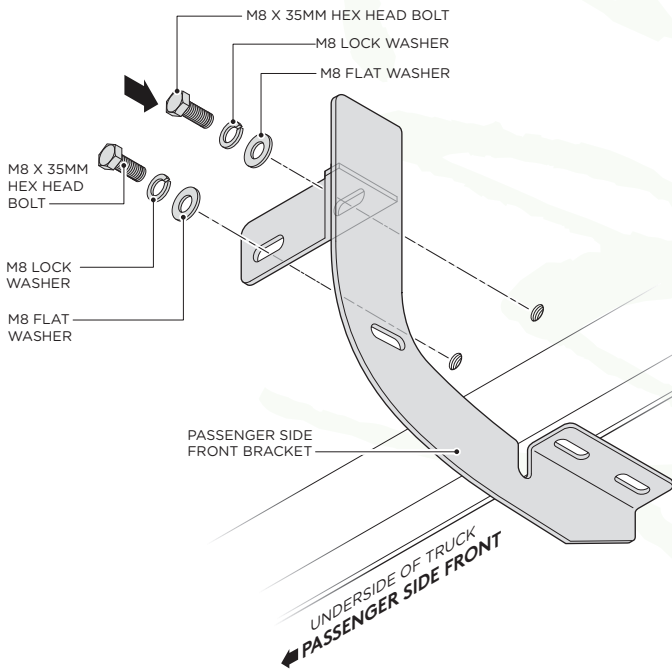

- 4.** Fasten the top portion of the Passenger Side Center Bracket by using (2) M8 x 30MM Hex Head Bolts, (2) M8 Flat Washers and (2) M8 Lock Washers.

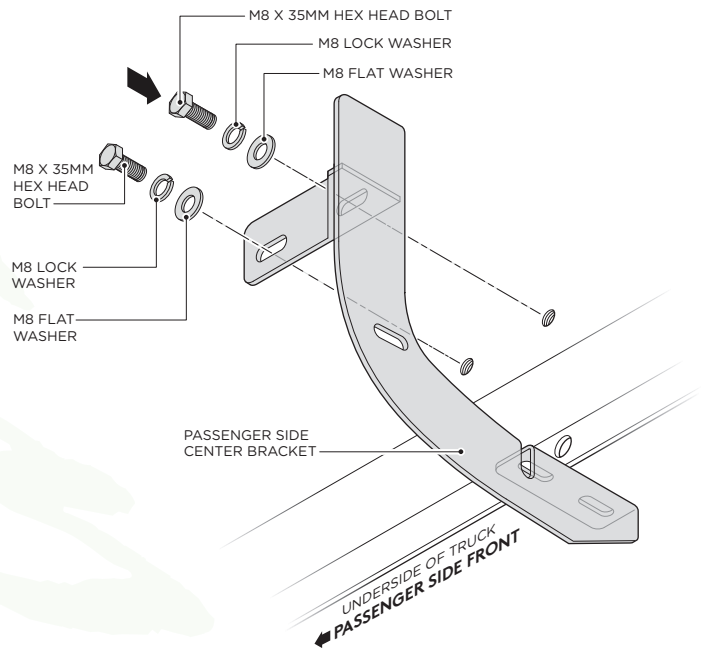

NOTE: NOT used on Regular Cab Models

- 5.** Fasten the top portion of the Passenger Side Rear Bracket by using (2) M8 x 30MM Hex Head Bolts, (2) M8 Flat Washers and (2) M8 Lock Washers.

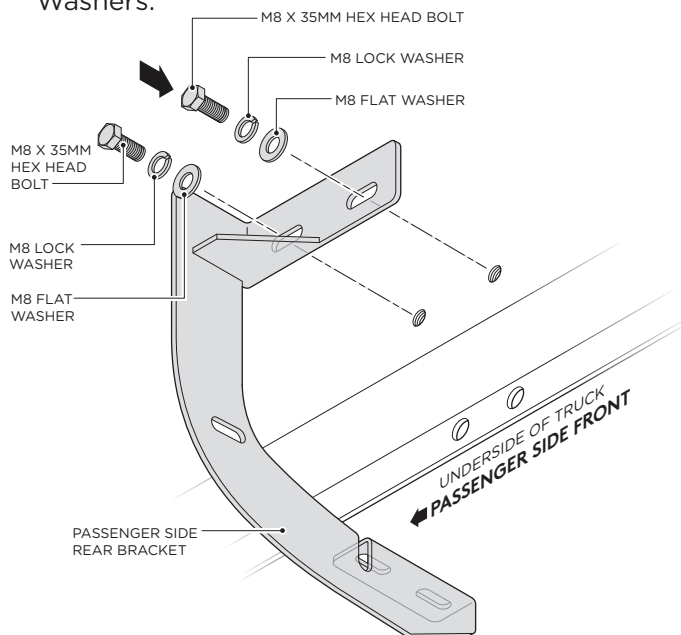

M8 BOLT + M8 NUT PLATE INSTALLATION

PASSENGER SIDE



If threaded inserts do not exist in your rocker panel holes, proceed with Step 6.

NOTE: Removal of tape or plastic plugs may be needed to expose factory holes.

NOTE: Use caution to not drop any hardware into your rocker panel!

6. Follow the steps shown below to install the M8 Bolt + M8 Nut Plate.

Insert M8 Bolt + M8 Nut Plate into top hole as shown.

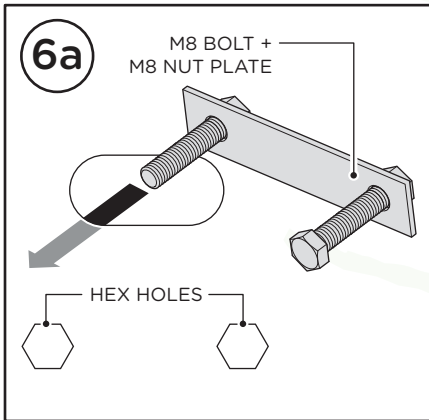

Rotate the threaded side of the M8 Bolt + M8 Nut Plate to the bottom left hole.

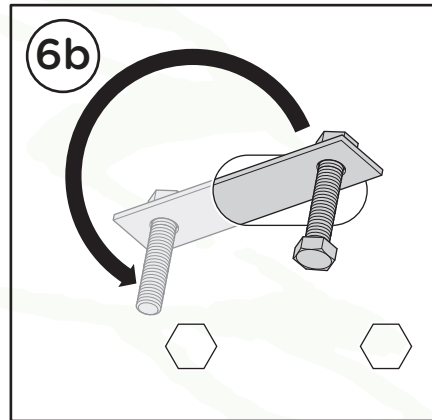

Pull the threaded side of the M8 Bolt + M8 Nut Plate through the bottom left hole.

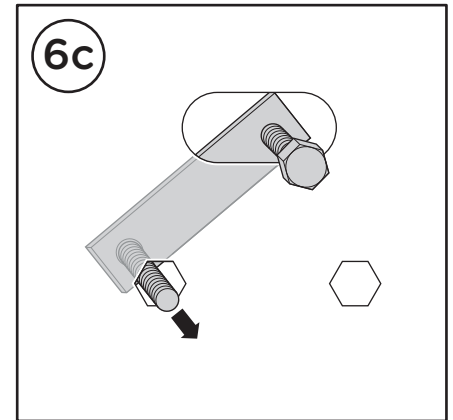

Install Plastic Retainer to ensure you do not drop the M8 Bolt + M8 Nut Plate into the rocker panel.

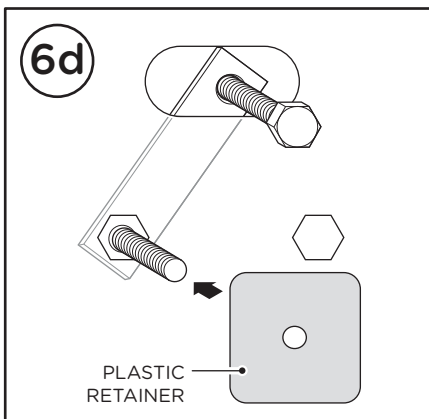

Remove the M8 Bolt from the M8 Nut Plate.

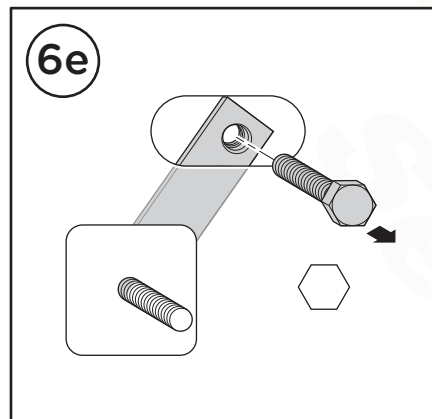

The M8 Nut Plate will now be able to rotate down to the hole in the rocker panel, allowing for bracket installation.

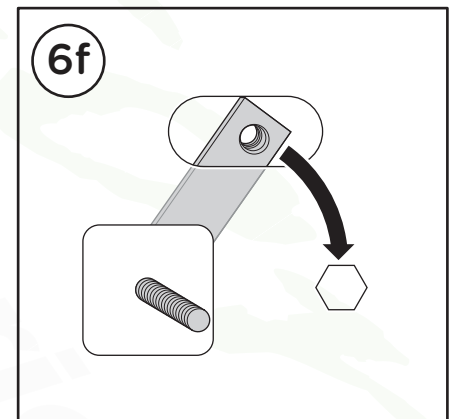

BRACKET INSTALLATION (WITHOUT THREADED INSERTS)

PASSENGER SIDE



7. Fasten the top portion of the Passenger Side Front Bracket to the bolt side of the M8 Bolt + M8 Nut Plate by using (1) M8 Flat Washer, (1) M8 Lock Washer and (1) M8 Hex Head Nut. Next, install the (1) M8 x 35MM Hex Head Bolt, (1) M8 Lock Washer and (1) M8 Flat Washer to the nut side of the M8 Bolt + M8 Nut Plate.

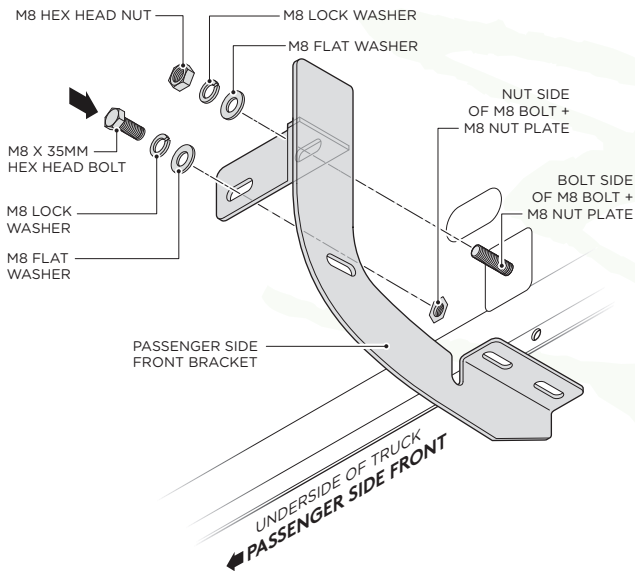

8. Fasten the top portion of the Passenger Side Center Bracket to the bolt side of the M8 Bolt + M8 Nut Plate by using (1) M8 Flat Washer, (1) M8 Lock Washer and (1) M8 Hex Head Nut. Next, install the (1) M8 x 35MM Hex Head Bolt, (1) M8 Lock Washer and (1) M8 Flat Washer to the nut side of the M8 Bolt + M8 Nut Plate.

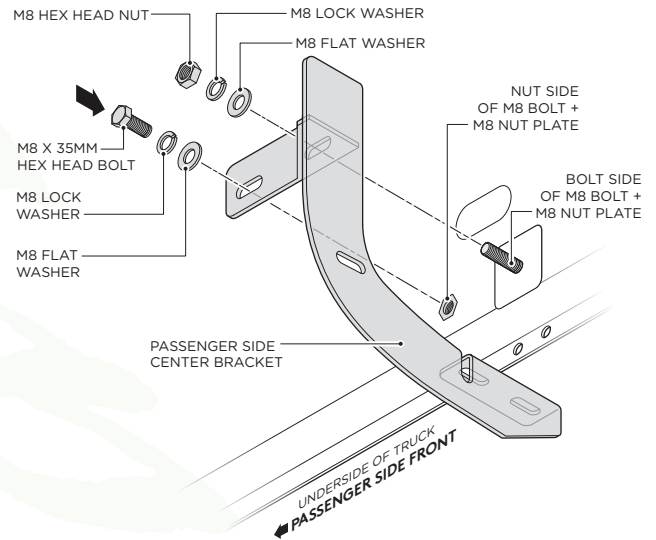

NOTE: NOT used on Regular Cab Models

9. Fasten the top portion of the Passenger Side Rear Bracket to the bolt side of the M8 Bolt + M8 Nut Plate by using (1) M8 Flat Washer, (1) M8 Lock Washer and (1) M8 Hex Head Nut. Next, install the (1) M8 x 35MM Hex Head Bolt, (1) M8 Lock Washer and (1) M8 Flat Washer to the nut side of the M8 Bolt + M8 Nut Plate.

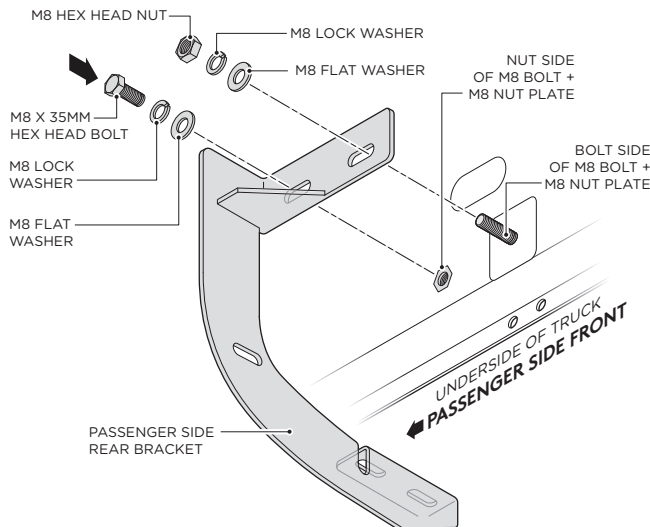

SUPPORT BRACE INSTALLATION

PASSENGER SIDE

Raptor
Series

- 10.** Fasten the top of the Passenger Side Front Support Brace to the rocker panel using (2) M8 x 30MM Hex Head Bolts, (2) M8 Flat Washers, (2) M8 Lock Washers and (2) M8 Hex Head Nuts. Then, fasten the bottom of the Passenger Side Front Support Brace to the Passenger Side Front Bracket using (1) M8 x 30MM Hex Head Bolt (2) M8 Flat Washers, (1) M8 Lock Washer and (1) M8 Hex Head Nut.

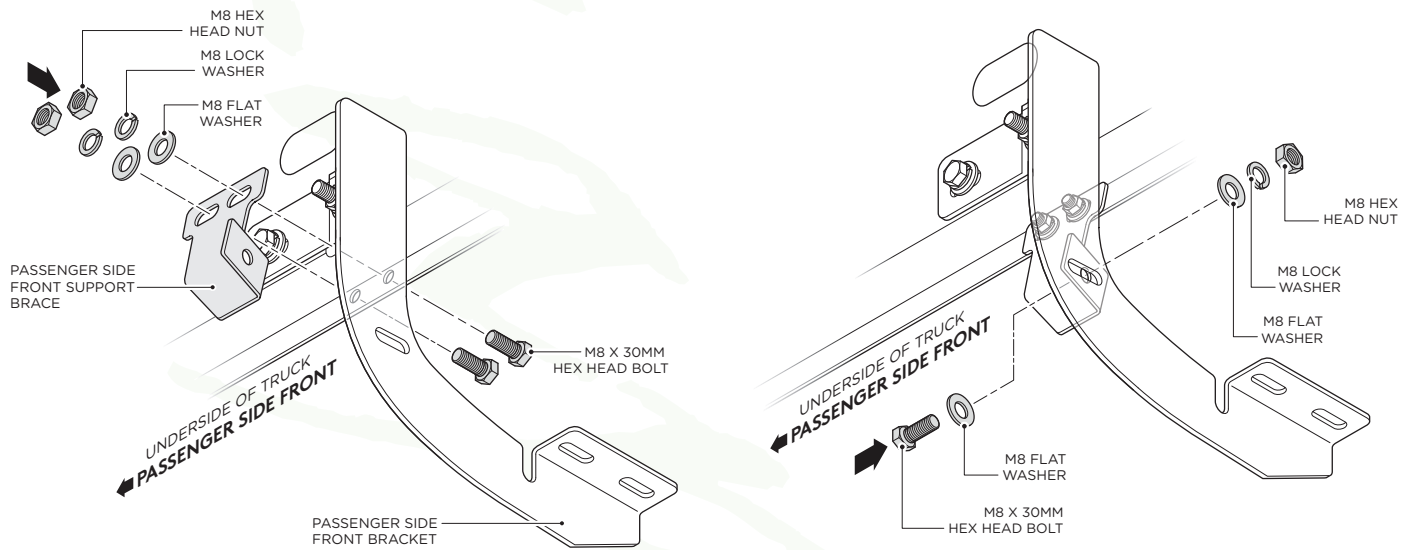

- 11.** Fasten the top of the Passenger Side Center Support Brace to the rocker panel using (2) M8 x 30MM Hex Head Bolts, (2) M8 Flat Washers, (2) M8 Lock Washers and (2) M8 Hex Head Nuts. Then, fasten the bottom of the Passenger Side Center Support Brace to the Passenger Side Center Bracket using (1) M8 x 30MM Hex Head Bolt (2) M8 Flat Washers, (1) M8 Lock Washer and (1) M8 Hex Head Nut.

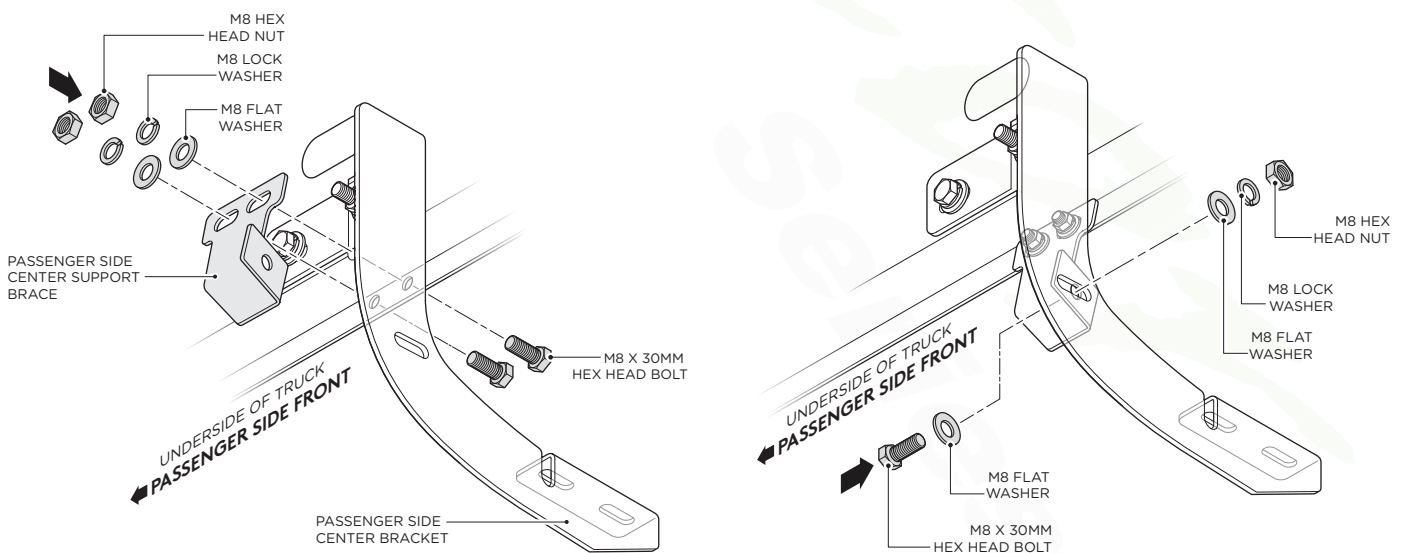

NOTE: NOT used on Regular Cab Models

SUPPORT BRACE INSTALLATION

PASSENGER SIDE

Raptor
Series

- 12.** Fasten the top of the Passenger Side Rear Support Brace to the rocker panel using (2) M8 x 30MM Hex Head Bolts, (2) M8 Flat Washers, (2) M8 Lock Washers and (2) M8 Hex Head Nuts. Then, fasten the bottom of the Passenger Side Rear Support Brace to the Passenger Side Rear Bracket using (1) M8 x 30MM Hex Head Bolt (2) M8 Flat Washers, (1) M8 Lock Washer and (1) M8 Hex Head Nut.

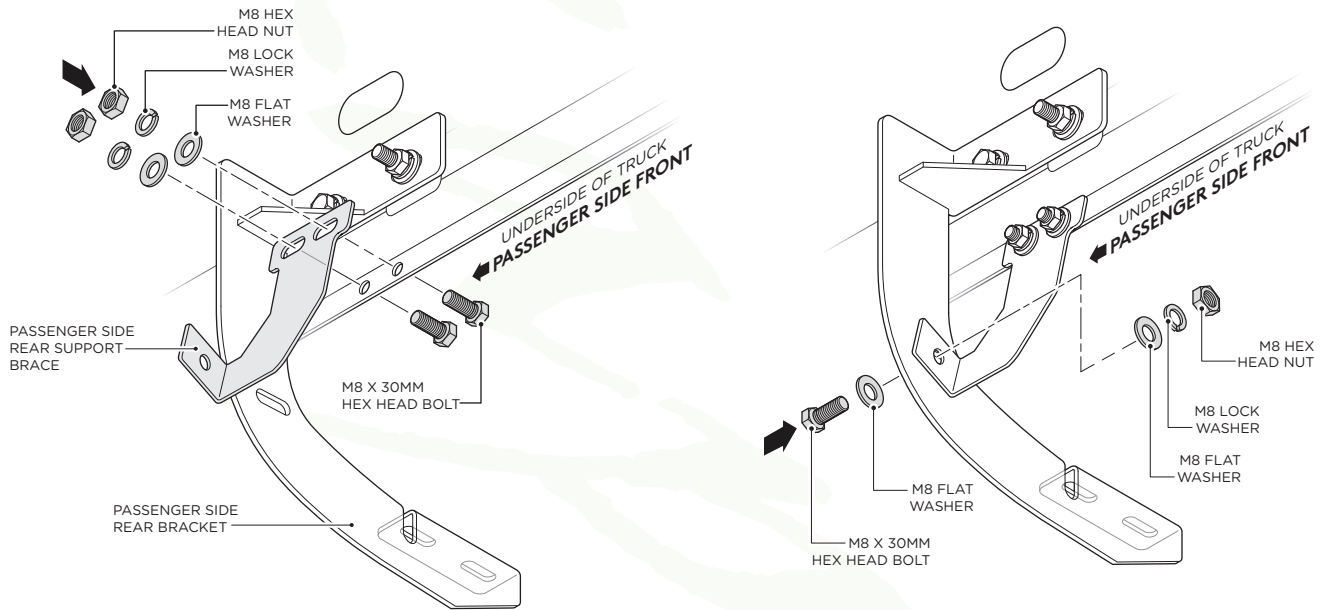

RUNNING BOARD INSTALLATION

PASSENGER SIDE



NOTE: Before proceeding to Step 13 see pages 16, 17, 18 for Board Installation Setup.

- 13.** Fasten the Running Board to the Passenger Side Front Bracket cradle by using (2) M8 Flat Washers, (2) M8 Lock Washers and (2) M8 Hex Head Nuts.

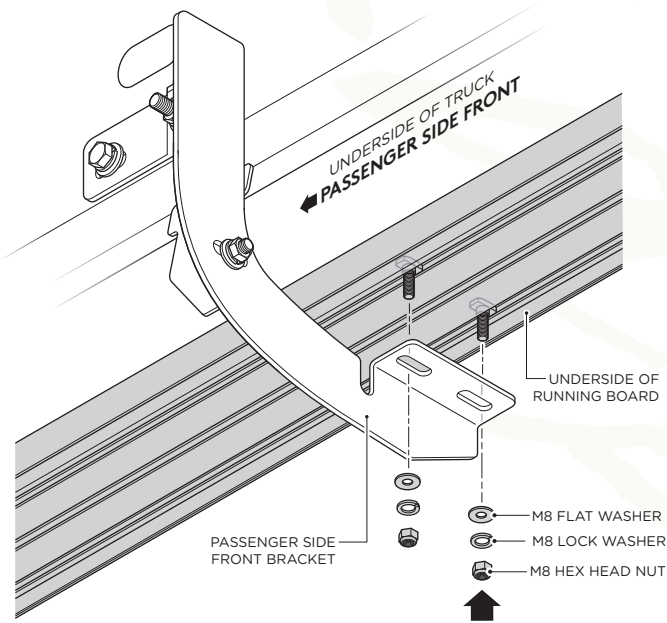

- 14.** Fasten the Running Board to the first Passenger Side Center Bracket cradle by using (2) M8 Flat Washers, (2) M8 Lock Washers and (2) M8 Hex Head Nuts.

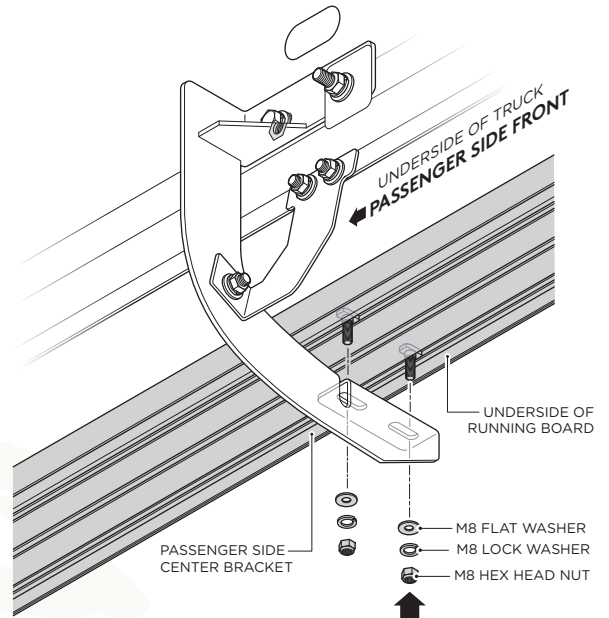

- 15.** Fasten the Running Board to the Passenger Side Rear Bracket cradle by using (2) M8 Flat Washers, (2) M8 Lock Washers and (2) M8 Hex Head Nuts.

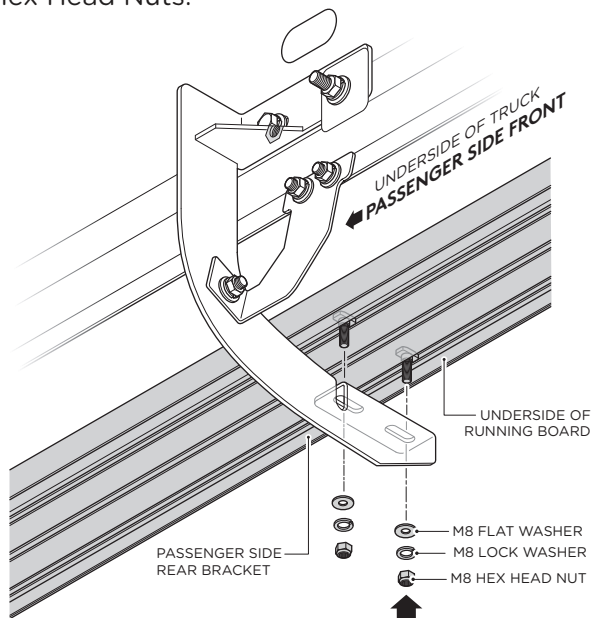

6.5" SAWTOOTH RUNNING BOARD ADAPTER PLATE INSTALLATION



1. Flip Running Board over. Place each Backing Plate and each Bolt Adapter Plate together (1a) and place onto underside of the running board and through the notch (1b). Slide plates into channels of running board and position plates so they line up approximately with existing mounting bracket location (1c).

Note: It might be helpful to position the underside of running board parallel to the existing mounting plates already installed on your vehicle, so you can align the Backing Plate/Bolt Adapter more accurately.

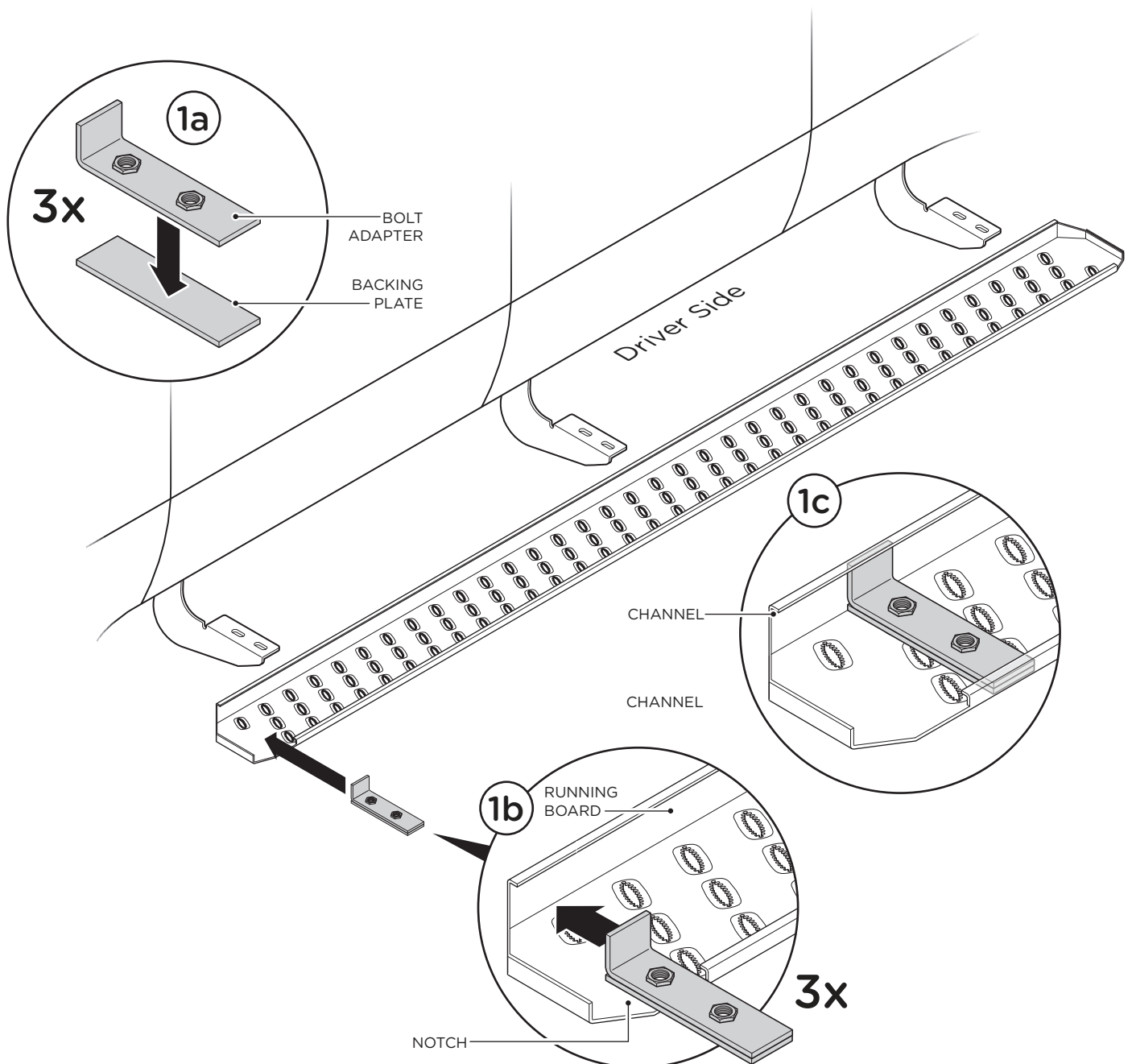

6.5" SAWTOOTH RUNNING BOARD ADAPTER PLATE INSTALLATION

Raptor
Series

2. You may need to adjust the plates slightly to align with the existing brackets (2a). Once aligned, insert provided allen drive studs into the holes on the Bolt Adapter Plate (2b), and finger tighten to hold both plates securely in place (2c), while still allowing for further adjustment to match up with vehicle mounting brackets. Repeat steps 1 and 2 for passenger side.

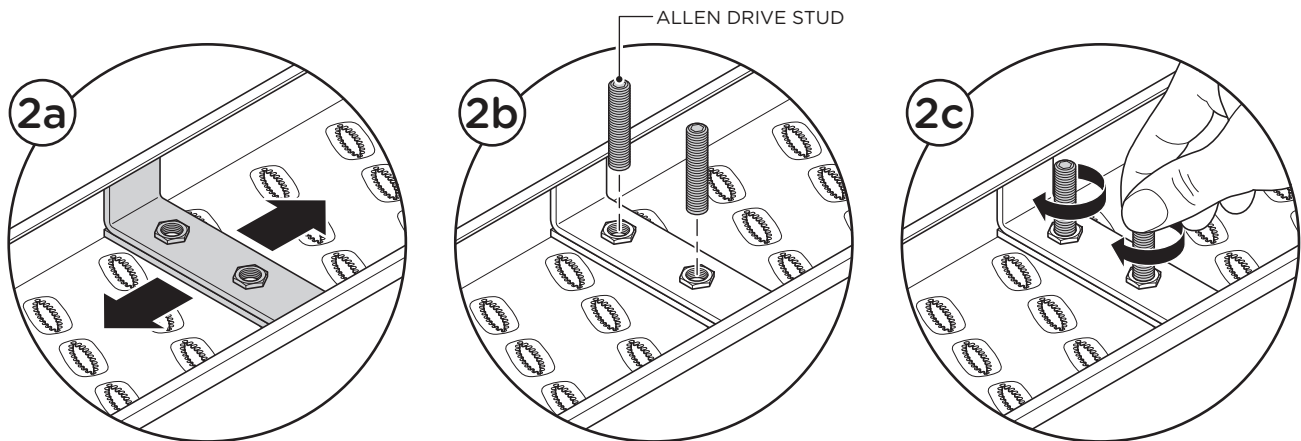
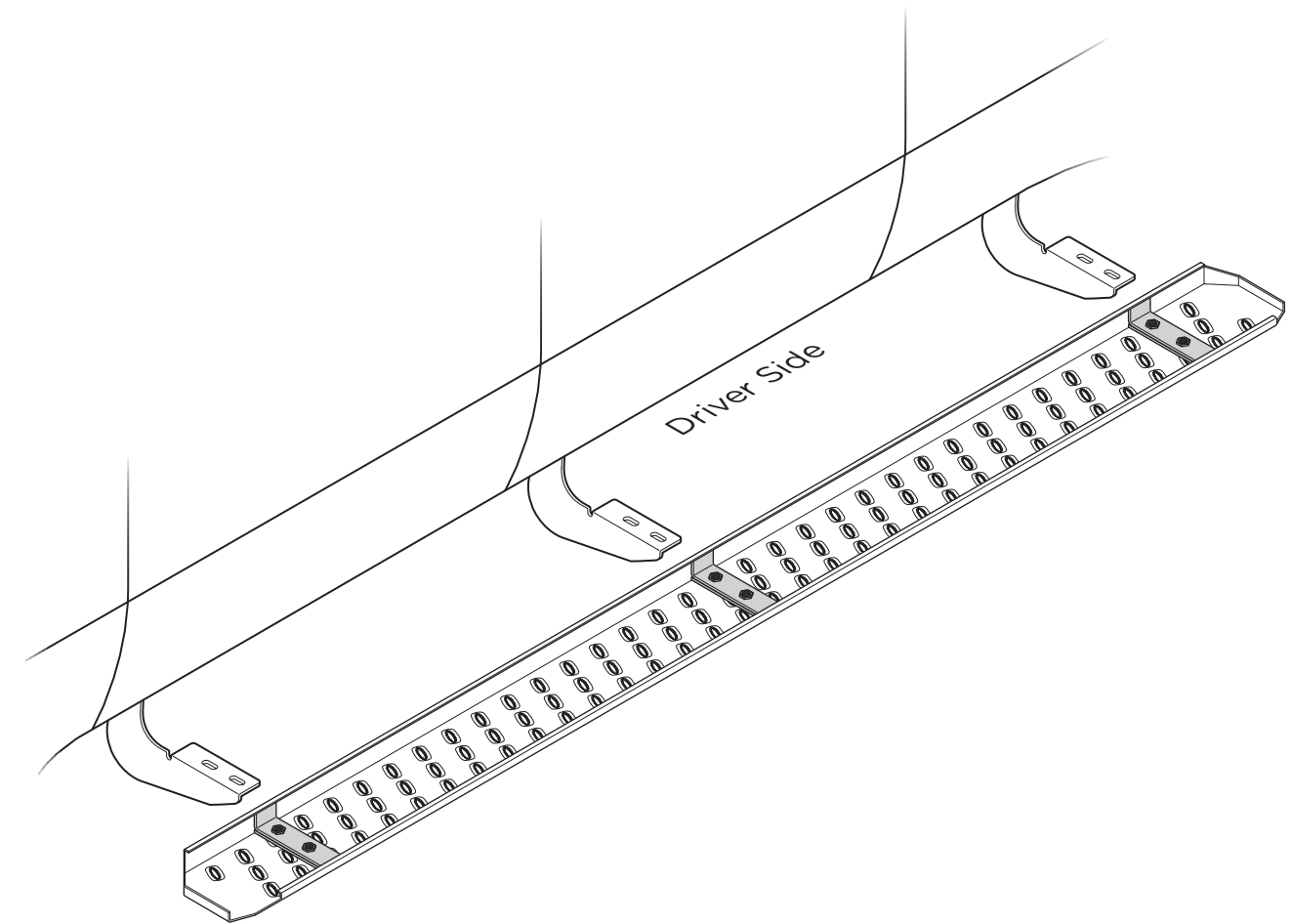

6.5" SAWTOOTH RUNNING BOARD BOARD INSTALLATION



3. Tighten allen drive studs with allen wrench (3a). Place Running Board on brackets (3b). Each running board is marked Driver and Passenger.

4. Align each allen drive stud with each hole in the bracket. Place the spacer plate in between the bracket and the board when installing.

5. Fasten Running Board on each bracket by using two (2) M8 Flat Washers, two (2) M8 Lock Washers and two (2) M8 Hex Head Nuts per bracket.

When all hardware is in place, everything must be tightened. Tighten until the split lock washer is flat between the M8 Flat Washer and M8 Hex Head Nut.

Repeat these steps for driver side installation.

